

Multi-Function Printer

User's Manual

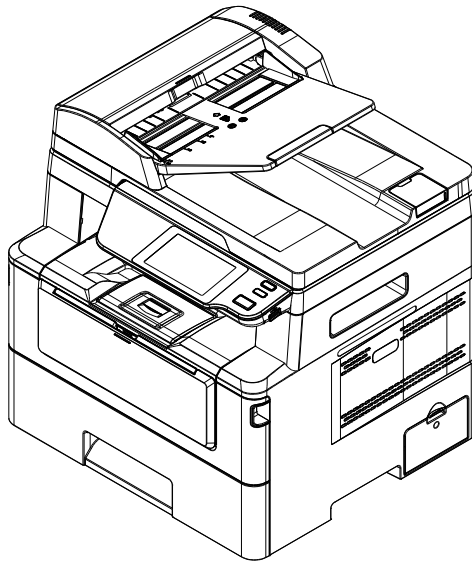

Regulatory model: AM40A Plus,
AM4032in Plus,AM4032iw Plus,AM4032ix Plus,
AM43A Plus,AM4332in Plus,AM4332iw Plus,AM4332ix Plus,
AM40 Series,AM43 Series

Avision Inc.

Trademarks

Microsoft is a U.S. registered trademark of Microsoft Corporation.

Windows 7, Windows 8, Windows 10, and Windows 11 are either registered trademarks or trademarks of Microsoft Corporation in the United States and/or other countries.

Energy Star® is a registered trademark of the U.S. government.

Other brands and product names herein are trademarks or registered trademarks of their respective holders.

Copyright

All rights reserved. No part of this publication may be reproduced, transmitted, transcribed, stored in a retrieval system, or translated into any language or computer language, in any form or by any means, electronic, mechanical, magnetic, optical, chemical, manual, or otherwise, without the prior written permission of Avison Inc.

Material scanned by this product may be protected by governmental laws and other regulations, such as copyright laws, the customer is solely responsible for complying with all such laws and regulations.

Warranty

The information contained in this document is subject to change without notice.

Avison makes no warranty of any kind with regard to this material, including, but not limited to, the implied warranties of fitness for a particular purpose.

Avison shall not be liable for errors contained herein or for incidental or consequential damages in connection with the furnishing, performance, or use of this material.

Notice

Important

- Do not make copies of any item for which copying is prohibited by law.
- Copying the following items are normally prohibited by the local law:
Bank bills, revenue stamps, bonds, stock certificates, bank drafts, checks.

FCC Caution:

Any changes or modifications not expressly approved by the party responsible for compliance could void the user's authority to operate this equipment.

This device is intended only for OEM integrators under the following conditions:

- 1) The antenna must be installed such that 20 cm is maintained between the antenna and users.
- 2) The transmitter module may not be co-located with any other transmitter or antenna.

Disposal of Waste Equipment by Users in Private Union



This symbol on the product or on its packaging indicates that the product can not be disposed of with your other household waste. Instead it should be sent to appropriate facilities for recovery and recycling in an effort to protect human health and the environment. For more information about where you can drop off your waste equipment for recycling, please contact your local city office, your household waste disposal service or the shop where you purchased the product.

When this printer has no operation for an extended period of time



Note: If the printer is idle for a period of time (for example, overnight), turn off the printer with the power switch. If the printer is idle for a longer period of time (such as holidays), unplug the power cord from the electrical outlet to prevent danger.

Take care to remove the paper from the paper tray and store it in the wrapper to prevent the paper from getting wet.

Federal Communications Commission (FCC) compliance information statement

Part 15

This equipment has been tested and found to comply with the limits for a Class B digital device, pursuant to Part 15 of the FCC Rules. These limits are designed to provide reasonable protection against harmful interference in a residential installation. This equipment generates, uses and can radiate radio frequency energy and, if not installed and used in accordance with the instructions, may cause harmful interference to radio communications.

However, there is no guarantee that interference will not occur in a particular installation. If this equipment does cause harmful interference to radio or television reception, which can be determined by turning the equipment off and on, the user is encouraged to try to correct the interference by one of the following measures:

- Reorient or relocate the receiving antenna.
- Increase the separation between the equipment and receiver.
- Connect the equipment into an outlet on a circuit different from that to which the receiver is connected.
- Consult the dealer or an experienced radio/TV technician for help.

This device complies with Part 15 of the FCC Rules. Operation is subject to the following two conditions: (1) This device may not cause harmful interference, and (2) this device must accept any interference received, including interference that may cause undesired operation.



European Union Regulatory Notice

Products bearing the CE marking comply with the following EU Directives:

- Low Voltage Directive 2014/35/EC
- EMC Directive 2014/30/EC
- Restriction of the use of certain hazardous substances (RoHS) Directive 2011/65/EU
- RED (Radio Equipment Directive) (2014/53/EC)



This product satisfies the Class B limits of EN55032, EN55035, and safety requirements of EN62368-1.

Safety Information

When using this equipment, the following safety precautions should always be followed.

Safety During Operation

In this manual, the following important symbols are used:

	WARNING: Indicates potentially hazardous situations, which if instructions are not followed, could result in death or serious injury.
	CAUTION: Indicates a potentially hazardous situation which, if instructions are not followed, may result in minor or moderate injury or damage to property.



Important:

Indicates operational requirements and restrictions. Please read and follow these instructions to ensure a proper operation and to avoid damage to the machine.



Note:

Indicates further explanation or clarification. Reading this is highly recommended.



The following symbols indicate that the related section includes safety warnings. Specific points of attention are indicated inside the symbol.

	[General warning]
	[Warning of high temperature]
	[Warning of danger of electrical shock]

The following symbols indicate that the related section includes information on prohibited actions. Specifics of the prohibited action are indicated inside the symbol.







	[Warning of prohibited action]
	[Disassembly prohibited]

The following symbols indicate that the related section includes information on actions which must be performed. Specifics of the required action are indicated inside the symbol.





	[Alert of required action]
	[Remove the power plug from the outlet]

Installation and the Operating Environment

Warning









Do not install the equipment near direct sun light, heating or air conditioning units. Direct sunlight or high temperature may damage the machine.	
Do not install the equipment in a humid or dusty place. If dust or dust adheres to the power plug, clean the plug to avoid fire or electric shock.	
Keep the vent hole on the back of the printer at least 10 cm away from the wall to avoid overheating and fire.	
Do not place or store the device: <ul style="list-style-type: none"> • Outdoors • Near excessive dirt or dust, water, or heat sources • In locations subject to shocks, vibrations, high temperature or humidity, direct sunlight, strong light sources, or rapid changes in temperature or humidity 	
Place the equipment securely on an even, flat surface. Tilted or uneven surfaces may cause mechanical or paper-feeding problems.	
Do not locate the device on rickety or aslope tables. Do not locate the device on unstable surface. The device may fall down and this may result in injury.	
Place the device close enough to the computer so that the interface cable can easily reach between the device and the computer.	
Do not place a coffee cup, vase, or other liquid-filled container on the machine. Spillage can damage the machine's electrical parts and insulation.	
Make good use of the recycled paper while printing.	





 **Caution**

Place the device in an independent, well-ventilated area.	
Place the device in a place with good environmental conditions. Operating the machine beyond the recommended temperature and humidity may cause an electrical fire.	
Do not place heavy objects on the unit. It may cause unbalance and the device may fall down. This may result in injury.	
Do not place the device in any position that may obstruct the output of the unit, as it may cause paper jams.	





Safety Information During Operation

 **Warning**

To prevent fires, do not use flammable sprays near the machine.	
Never attempt to open any fixed cover. Otherwise there is danger of electric shock, fire and laser beam and may cause blindness.	
Never disassemble, modify, or attempt to repair the device or device option by yourself, except as specifically explained in the device's documentation. This could cause fire, electrical shock, or injury.	
Do not attempt to alter the machine or its parts. Avoid contact with the internal high voltage part or the laser light beam, it may cause electric shock or blindness.	
If this product becomes inordinately hot or emits smoke, or unusual odor or noise, immediately turn OFF the power switch, unplug the power cord from the power outlet, and then call your authorized service representative. If you keep on using it as is, a fire or electrical shock could result.	
Take care not to drop paper clips, staples, or any other metal objects into the machine.	
The inside of this product has areas subject to high temperature, which may cause burns. When checking the inside of the unit for malfunctions such as paper mis-feed, do not touch the locations (around the fusing unit, etc.) which are indicated by a "Caution! Hot Surface" caution label.	
Under normal conditions the small quantities of ozone gas produced by the machine are harmless. However, if the machine is used for an extended period or within a small room, you should make sure that the area is adequately ventilated. Also ventilate the room if you notice the machine smells after a period of frequent or extended use.	
Do not attempt to remove the covers and panels which have been fixed to the product. Some products have a high-voltage part or a LSU beam source inside that could cause an electrical shock or blindness.	



<p>Do not modify this product, as a fire, electrical shock, or breakdown could result. If the product employs a LSU printhead, the LSU beam source could cause blindness.</p>	
<p>If this product has been dropped or its cover damaged, immediately turn OFF the power switch, unplug the power cord from the power outlet, and then call your authorized service representative. If you keep on using it as is, a fire or electrical shock could result.</p>	
<p>Take appropriate emergency measures when the following conditions occur</p> <ul style="list-style-type: none"> • When toner gets into your eyes, wash it off with water until your eyes are not painful. If the situation is serious, ask a doctor for treatment. • When the toner gets on your skin, wash it off with soap and rinse it off. • When you are in the toner inlet, leave the dust location immediately and rinse with plenty of water. • When the toner is in the abdomen, spit it out and consult a doctor. 	
<p>Do not use the device with wet hands.</p>	
<p>Unplug the device and the USB cable, and refer servicing to qualified service personnel under the following conditions:</p> <ul style="list-style-type: none"> • Liquid has entered the device. • Object has entered the device. • The device has been dropped, or the case has been damaged. • The device does not operate normally (i.e. appearance of smoke, strange smell, odd noise, etc.), or exhibits a distinct change in performance. 	

 **Caution**



<p>When there is paper jam inside the machine, be sure to remove it thoroughly. The remaining paper in the machine may cause a fire. When the paper is attached to an invisible or difficult-to-see area, do not remove it by force to avoid injury and contact the service personnel or dealer for help.</p>	
<p>The temperature inside of the machine may be very hot. When the paper jam is released, note any warning labels and do not touch it to avoid burns. It is recommended to clear the jam after the machine has cooled down.</p>	
<p>When clearing paper jams, refer to the instructions in this manual.</p>	
<p>When using a large number of copies of the machine for a long time, keep the indoor air flowing. Otherwise you may feel a headache.</p>	
<p>Unplug the device's power cord and USB cable before cleaning.</p>	

About the Consumables

Warning







<p>Do not unpack the consumables and store the machine's consumables in any of these locations:</p> <ul style="list-style-type: none"> • Outdoors • Near excessive dirt or dust, water, or heat sources • In locations subject to shocks, vibrations, high temperature or humidity, direct sunlight, strong light sources, or rapid changes in temperature or humidity 	
<p>Do not throw the toner cartridge into the fire. After the toner remaining in the crucible comes into contact with the fire, the powder may explode and cause personal injury.</p>	

Caution

<p>Do not discard the discarded toner cartridges. Please put the used waste toner cartridges in the supplied plastic bags and return them to the dealer or service personnel. (For the customer service locations around the company, please refer to our website.). The latter will recycle the used toner cartridge in accordance with relevant regulations.</p>	
<p>The used consumables must be disposed of properly and in accordance with local environmental regulations, or disposed of by the company's designated dealer.</p>	



Safety Information When using power cord and the USB cable

Warning

<p>Plug the power cord securely into the outlet. Do not touch the pins of the power cord plug with any metal objects as they may touch dangerous voltage points or short circuit. This can cause fire, electric shock or injury. Failure to do so may result in a fire or electric shock.</p>	
<p>Before disconnecting the plug, turn the machine off. Make sure your hands are dry. Hold the plug itself, not its cord, when disconnecting it from the receptacle.</p>	
<p>Do not share the power with other high-powered devices, as this may result in fire or electric shock.</p>	
<p>Do not use extension cords as this may result in fire or electric shock.</p>	
<p>Always use the correct AC power source. For future transportation and handling, please keep all packaging materials for this product.</p>	
<p>Use only the USB cable that came with your device and avoid abrasions, cuts, fraying, crimping, and kinking. Using any other USB cable could cause fire, electrical shock, or injury.</p>	
<p>Do not store the cables in the following locations:</p> <ul style="list-style-type: none"> • Outdoors • Near excessive dirt or dust, water, or heat sources • In locations subject to shocks, vibrations, high temperature or humidity, direct sunlight, strong light sources, or rapid changes in temperature or humidity 	

Keep the supplied USB cable, etc., in a location that is out of reach of children to avoid the risk of injury.	
Please put the packaging materials such as the supplied plastic bags in a place that children cannot obtain or discard them to avoid the risk of suffocation.	

 **Caution**

If you are not using the device for a long time, remove the USB cable from the connector.	
This product has a power-saving mode and a standby mode. The zero-energy state can be achieved only when the product is connected without any external input power.	
At least every year, please disconnect the power cord from the wall outlet to check whether the power cord is exposed, damaged, cracked, dent, hot, pin deformation or any burnt marks. If these conditions exist, please do not use the power cord again and contact the authorized service personnel or dealer.	
Make sure the power cord is plugged into a grounded electrical outlet, otherwise it may cause a fire or electric shock.	
Be sure to fully plug the power cord into a wall outlet. Failure to completely insert may cause unstable connections and heat build-up, creating an unsafe condition.	
When disconnecting the power cord from the wall outlet, be sure to pull the plug, not the power cord, as this may damage the power cord and cause a fire or electric shock.	
To repair the machine, be sure to disconnect the power cord from the wall outlet.	
Make sure the power cord is firmly secure and will not trip over.	
Risk of explosion if battery is replaced by an incorrect type. Dispose of used batteries according to the instructions or equivalent.	
This product requires connection to protective earth by means of powercord(s) connected to socket-outlet(s) with protective earthing connection.	

SAFETY INSTRUCTION

This printer is a page printer which is operated by means of a LPH (LED Print Head). There is no possibility of danger from the laser printhead, provided the printer is operated according to the instructions in this manual. Since radiation emitted by the laser printhead is completely confined within protective housings and external covers, the laser beams cannot escape from the machine during any phase of user operation.

1. Overview

Introduction – the World’s Renown Copier

Congratulations on your purchase of the world's renowned intelligent copier. With the innovative intelligent copy function, users no longer need to specify the size of document, worry about whether the document has been loaded straight and correct, or if the document should be faced down or up, the Avision intelligent copier is able to crop your paper size, select the text side, straighten your image, and even select proper paper tray automatically! The Avision intelligent copier truly makes your copy job perfect and easy!

What is best, the Avision intelligent copier integrates scan, copy, and print functions into one single machine to streamline your workflow. Through the 4.3” color and clear LCD touch screen and the easy-to-use control panel, your task can be completed within seconds and your document can be distributed and shared very quickly in an unprecedented way!

Features

Placing Your Document with Ease

With the auto crop and straighten function, users no longer need to carefully place document to the edge of paper guides. Even the document has been placed at a slight angle in the feeder or on the document glass, the image can be first scanned, cropped and then straightened automatically.

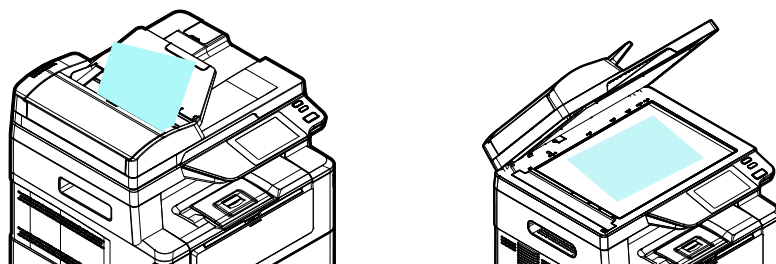

Easily placing your document to the feeder or on the flatbed glass

Automatically Detect the Text Side

With an advanced processor developed by Avison, the front side and rear side of document can be scanned simultaneously and the text side will be automatically detected and copied and deleting the blank side.

Automatically Selecting the Paper Tray

The preset tray is auto which means the product will automatically select the tray which contains the paper size most fit to the original document.

Intelligent Copy

Avison intelligent copier can make copy automatically after detecting your document passing through the document feeder. Plus with the preview feature, user is able to choose one-side or two-side copy and verify if the image is correct.

Duplex (2-Sided) Capability

Use the automatic duplex printing feature to help save paper and reduce costs.

Scan to Device, and USB

The product offers an unprecedented document storage technology, transmitting paper documents electronically to the product's memory or to a removable USB flash drive.

Scan to E-mail, FTP, or SMB

The product offers an unprecedented document delivery technology, transmitting paper documents electronically over the internet to various destinations including e-mail addresses, an USB flash drive, ftp servers, or someone else's computer on the network. The new way to distribute documents is faster, more cost effective, and safer than any traditional methods such as mail, or courier.

Remote Device Management via the Embedded Webpage

The product provides an embedded web page to let the system administrator remotely monitor the product by managing a telephone book, address book, checking the supplies status of toner cartridge, scan count, copy count, and creating user password and privileges to prevent unauthorized access.

Easy Customization

This product makes user customization fast and easy by simply installing a third-party app (short for application) to be run on the product. The new plug-in app allows users to complete the scan tasks according to its own workflow. For more detailed operation, please contact the manufacturer first.

The External View

The Front View

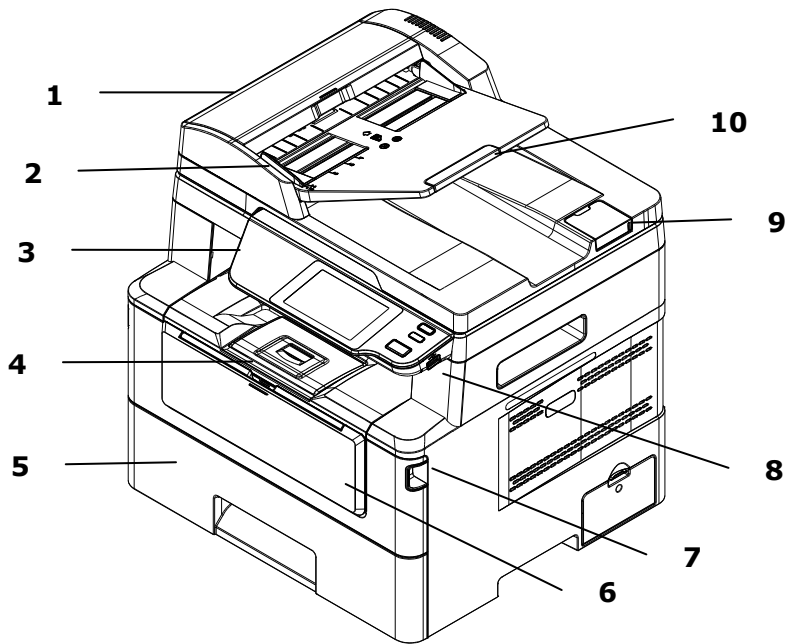

1. Auto Document Feeder	6. Manual Tray
2. Paper Guide	7. Handle of Front Tray
3. Control Panel	8. USB Port (USB Flash Drive, FAT16/FAT32)
4. Paper Stopper	9. Document Cover
5. Main Paper Tray	10. Extension

The Rear View

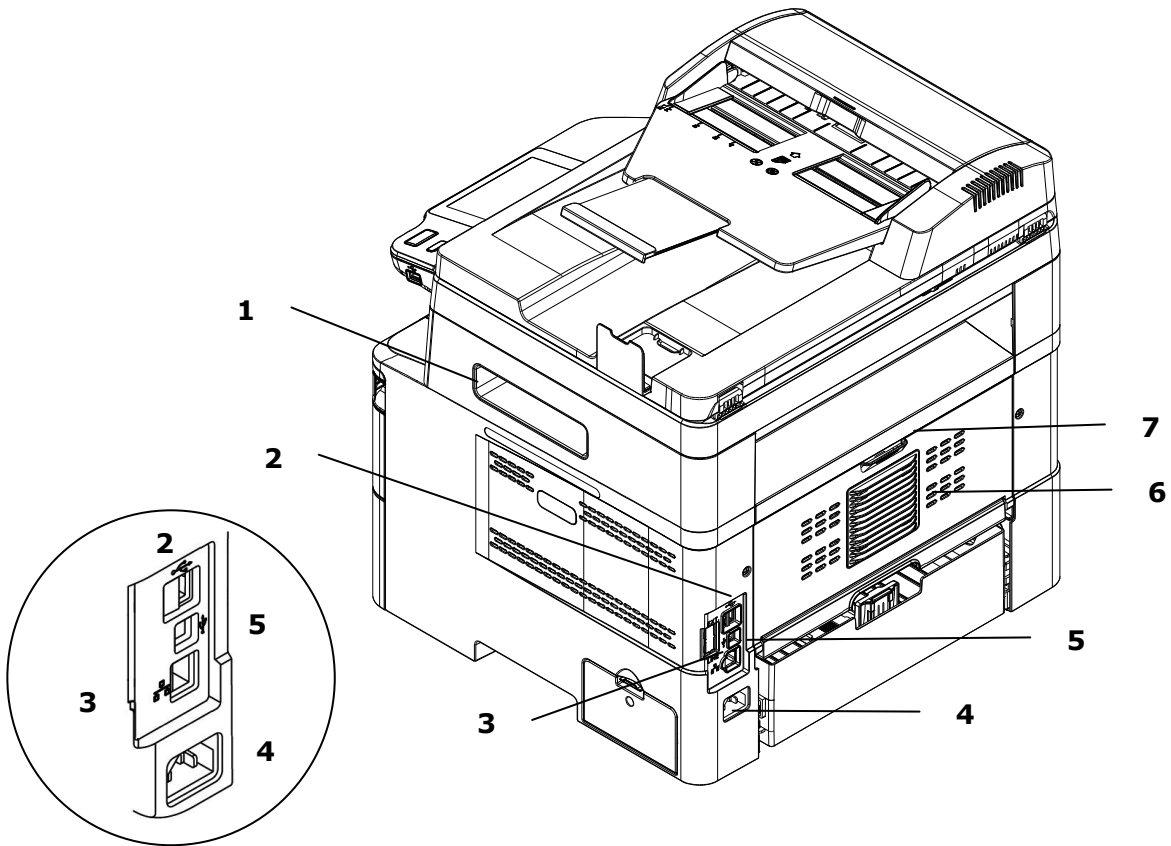

1. Handle of the Side Cover	5. USB Port (Type B, to a computer)
2. USB Port (Type A)	6. Rear Cover
3. Network Port	7. Handle of the Rear Cover
4. Power Receptacle	

Package Contents

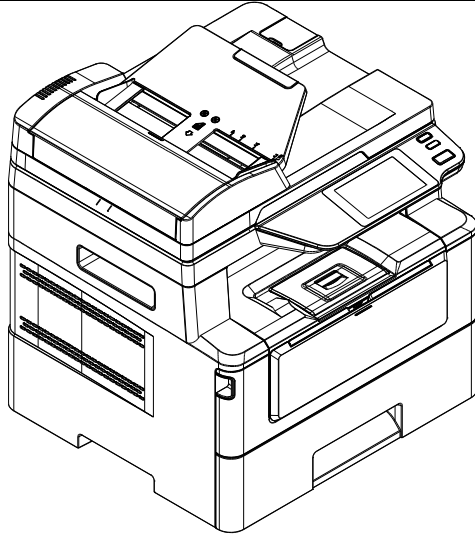

Main Unit

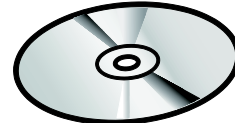

CD-ROM (Including Driver, and User's Manual)

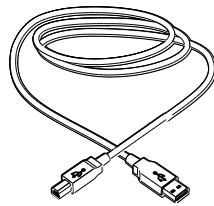

USB Cable

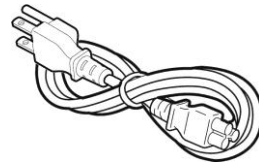

Power Cord

Control Panel

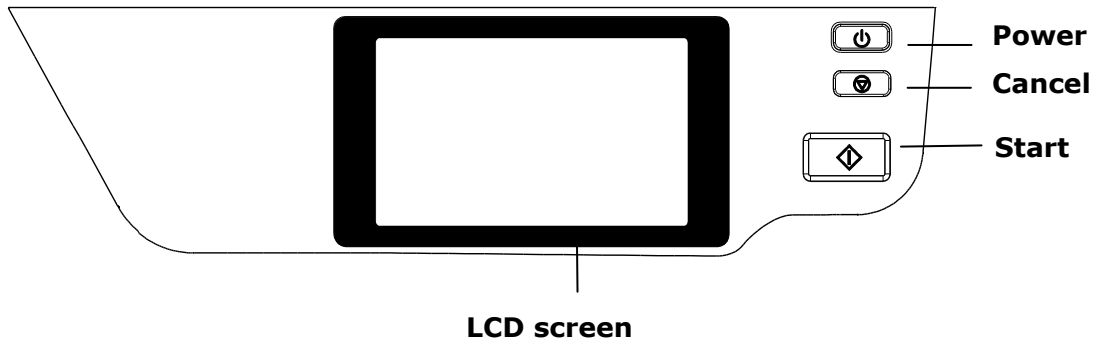

LCD screen	Used to display information and provide access to the product's functions.
Power	Press to turn on the machine. Long press to turn off the machine.
Stop/Cancel	Press to pause a current job.
Start	Press to start an operation.

2. Installing Your Machine

Precautions

- Do not install the equipment near heating or air conditioning units.
- Do not install the equipment in a humid or dusty place.
- Place the equipment in a separate area with good ventilation.
- The equipment is equipped with both the power-saving and standby modes.
The equipment can not achieve zero energy consumption state until it is not connected to any external power supply.
- Be sure to use the correct AC power supply.
- Retain the box and packing materials for shipping purposes.

Operational Space

Please reserve the following operation space.

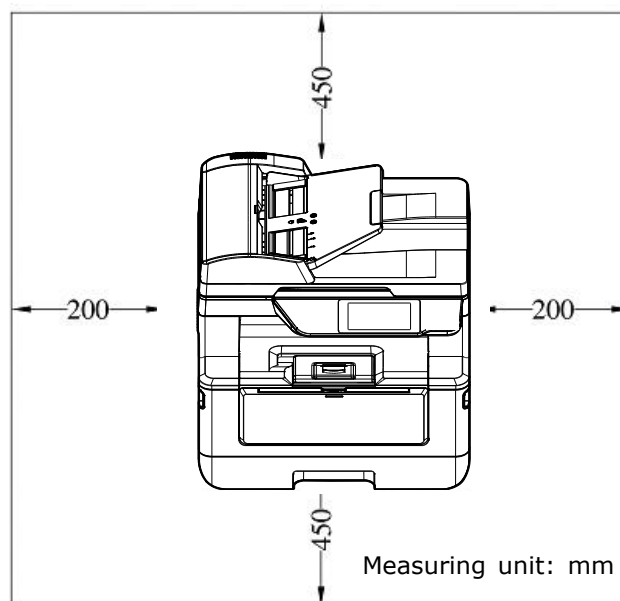

Machine dimension: 404 x 380 x 413 mm (WxDxH)

Removing the Protective Tapes

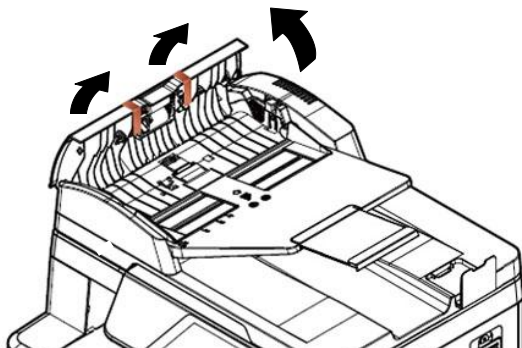
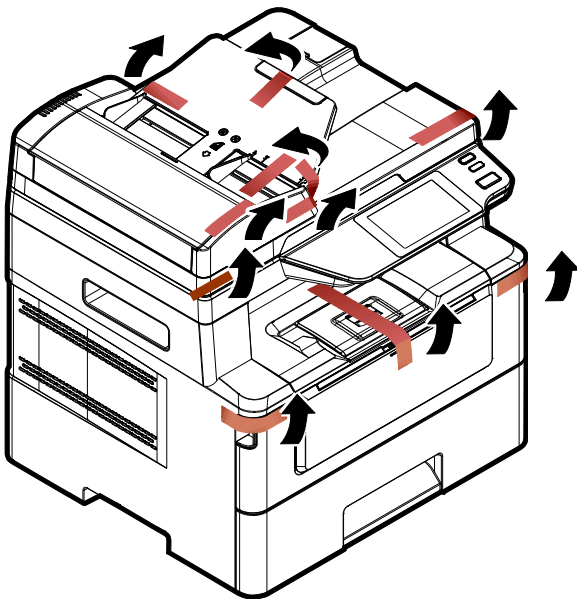

Open the Auto Document Feeder and remove the tapes

Removing the Packing Materials

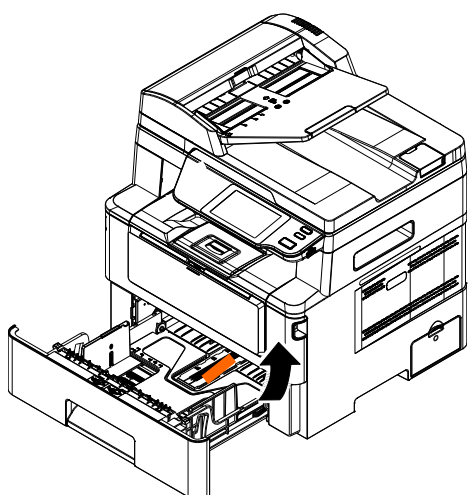

Pull the Paper Tray and remove the packing material.

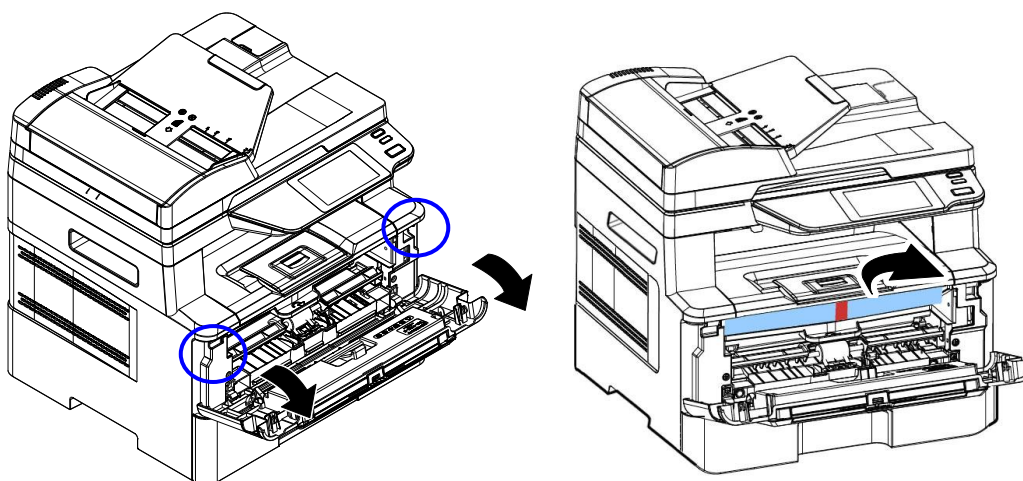

Open the front cover and remove the packing material.

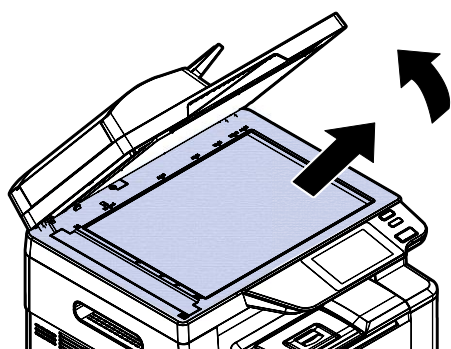

Open the document cover and remove the packing material.

Removing the Spacers

1. Open the rear cover by pulling the handle of the rear cover.

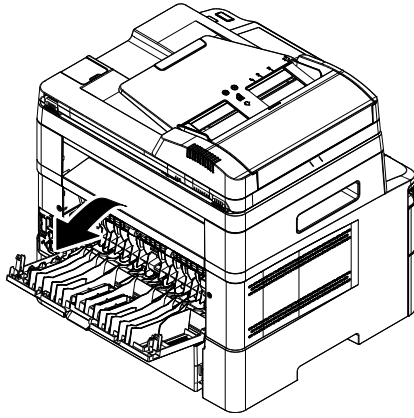

2. Pull down two ends of the paper path.

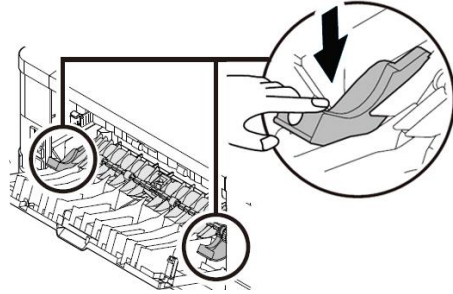

3. Pull down the green release arms as indicated.

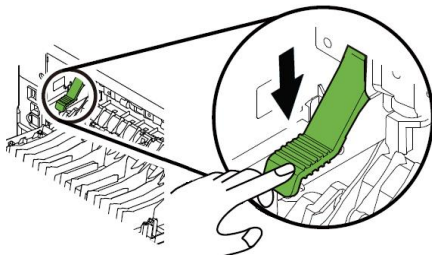

4. Remove the spacers on both sides as illustrated.

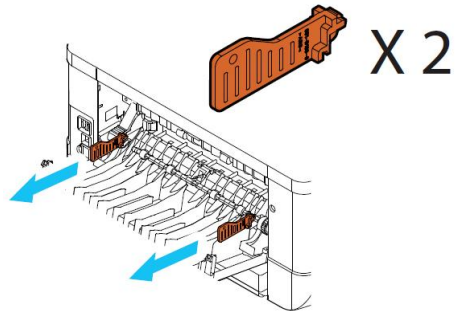

Installing the Toner Cartridge

Please follow these steps to install the toner cartridge:



Warning!

- Be careful not to inhale toner.
- If toner gets on your clothing or other fabric, wipe off the toner with a dry cloth. Wash the items in cold water and air dry.

1. Open the front cover by pulling the handles on both sides as shown.

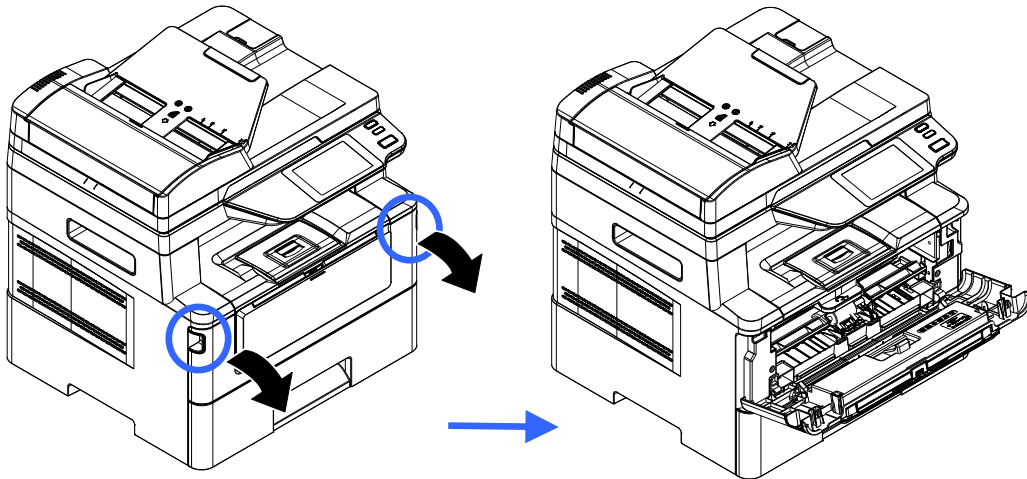

2. Hold the handle of the drum unit and pull it out as shown.

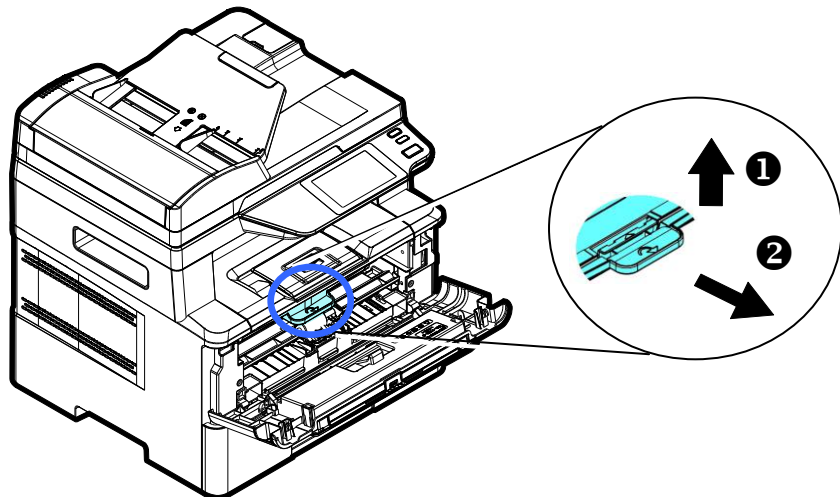

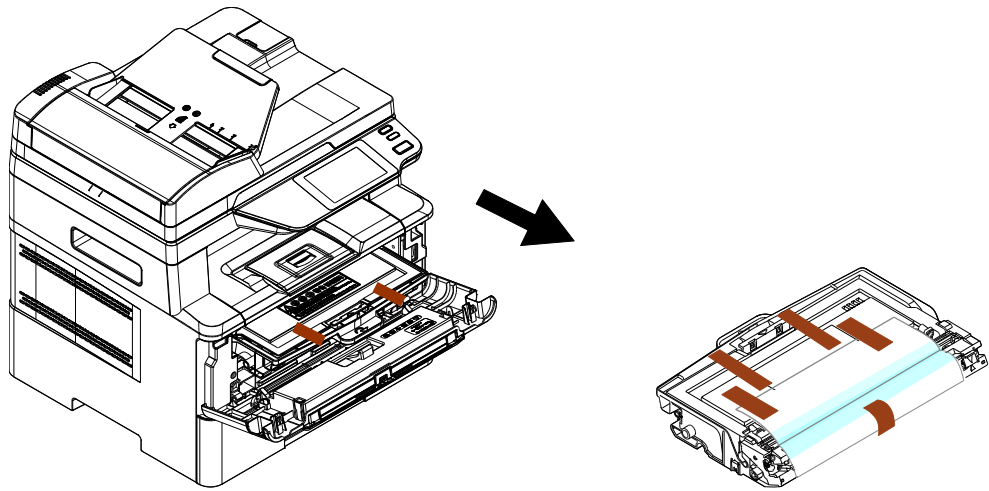

3. Remove all the tapes, protective sheets on the drum and toner cartridge assembly.

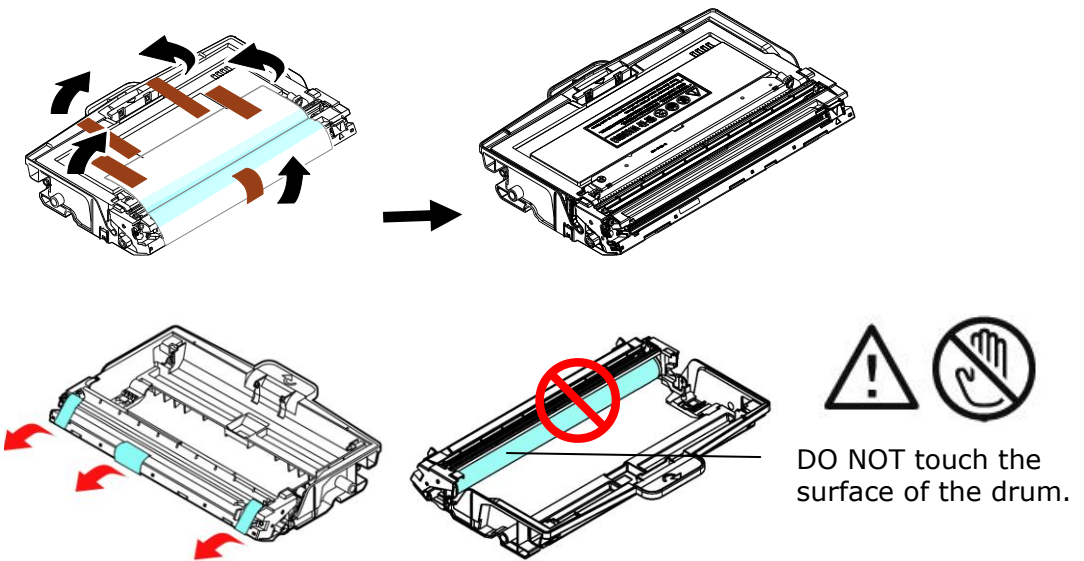

Warning!

- To avoid print quality problems, DO NOT touch the toner rollers.
- To prevent the toner cartridge from damage, do not expose it more than several minutes.

4. Push the latch in the middle of the toner cartridge forward in the direction of the arrow to separate the toner cartridge from the drum.

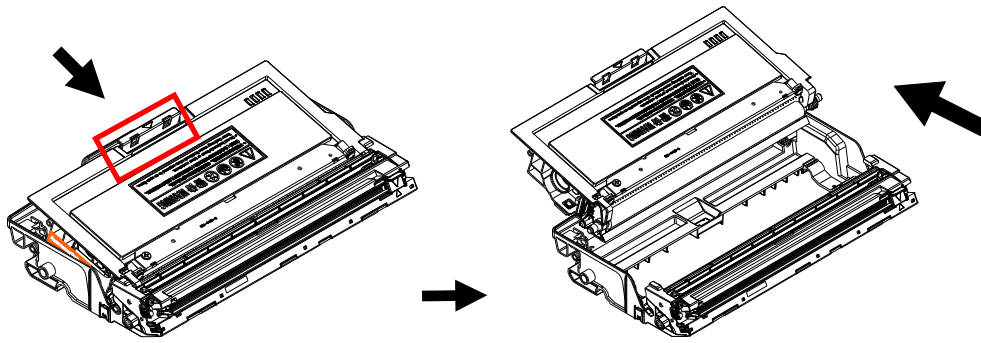

5. Pull out the protective seal of the toner cartridge until it is completely removed.

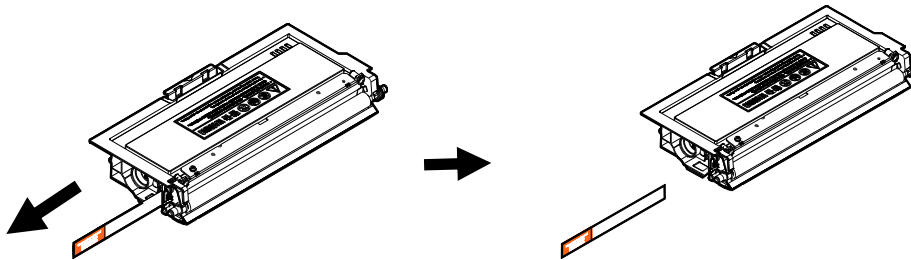

6. Tilt the new toner cartridge up and down and then right and left 10 times to distribute the toner evenly inside the toner cartridge.

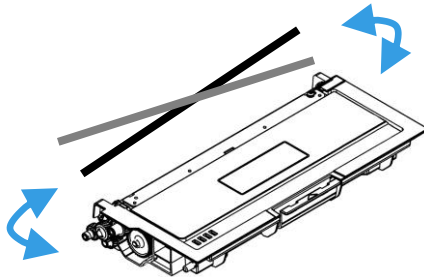

7. Install the toner cartridge to the drum unit until you hear it lock into place.

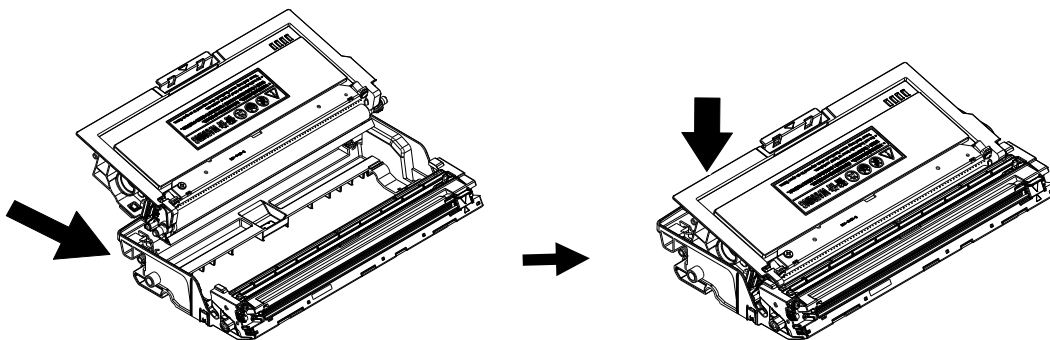

8. Hold the handle of the drum unit and toner cartridge assembly and insert the assembly to its original place.

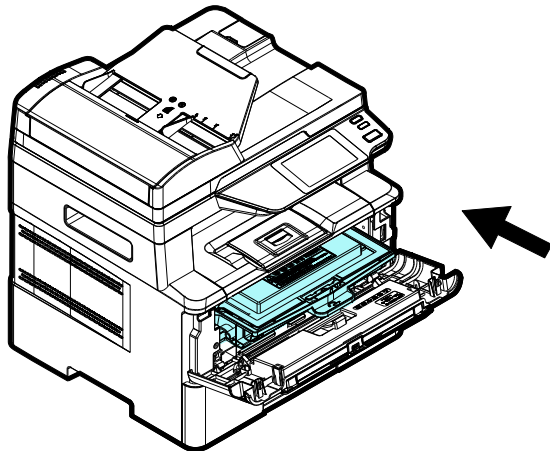

9. Press down the toner cartridge to fix it into place.

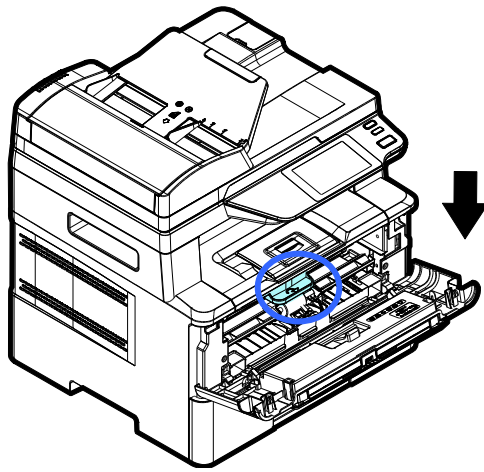

10. Close the front cover.

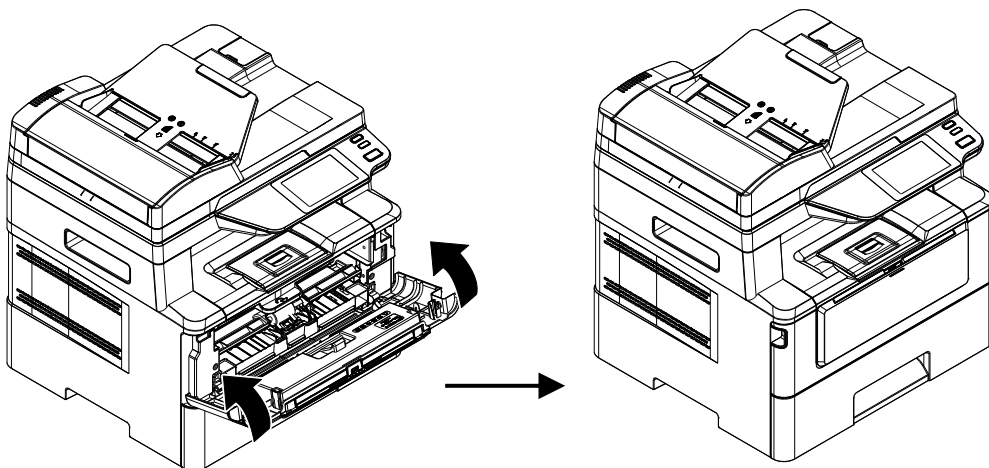

Installing the Paper Stopper

Raise the Paper Stopper and then its support to collect your paper.

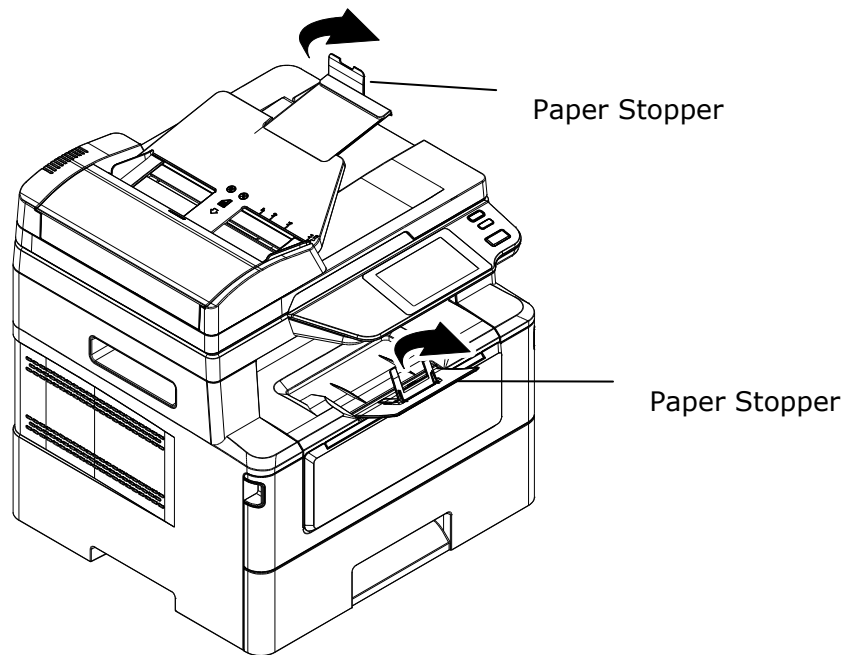

Loading Paper to the Main Input Tray

To insert paper to the main input tray,

1. Fan your paper first to ensure that the pages do not stick together.

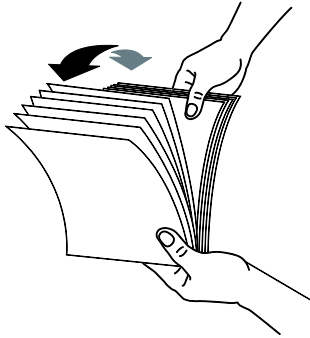

2. Align the edges of the documents by tapping the bottom of the stack against the table top. Rotate the stack 90 degrees and repeat.

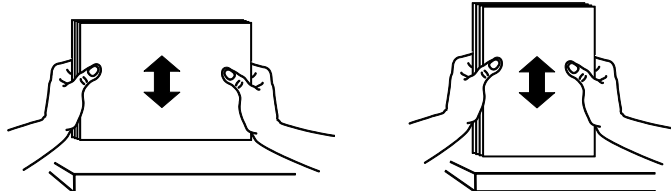

3. Pull the main tray out gently.

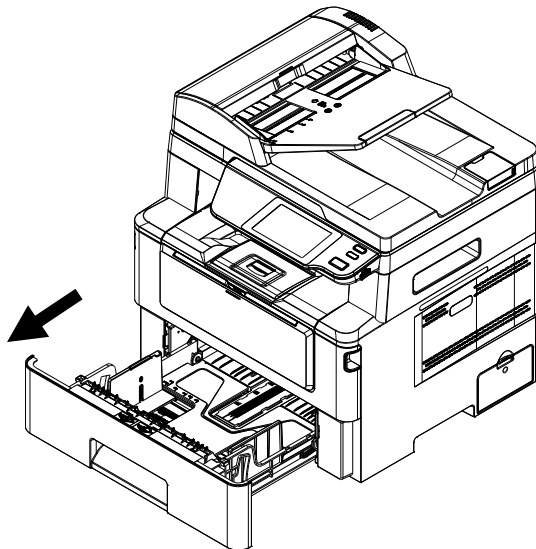

4. Lift the center of the width guide tab (①), and move the width guide (②) to the correct position for the paper size being loaded.

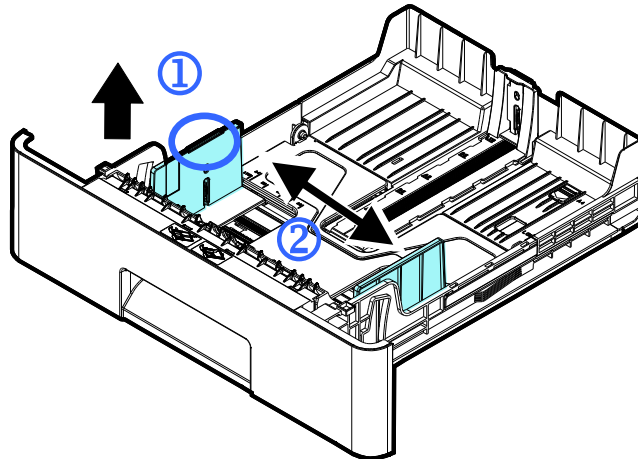

5. Lift the center of the length guide (③), and slide the guide (④) to the correct position for the paper size being loaded.

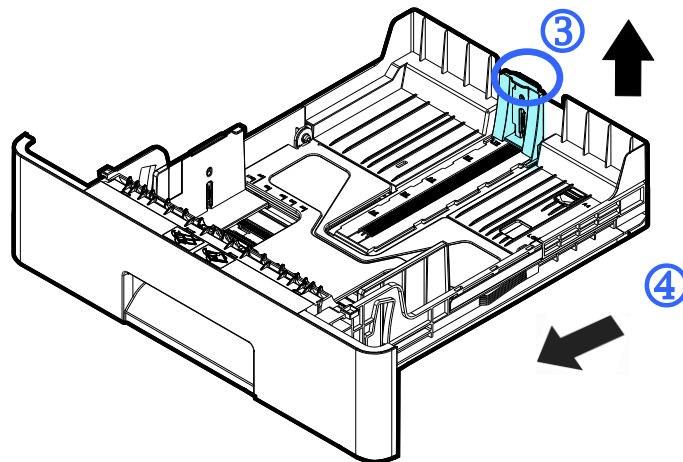

6. If you want to load a sheet of paper larger than the length of A4, press down the length adjustment latch (⑤), and at the same time slide the manual tray to the left (⑥) until it reaches the paper size you want.

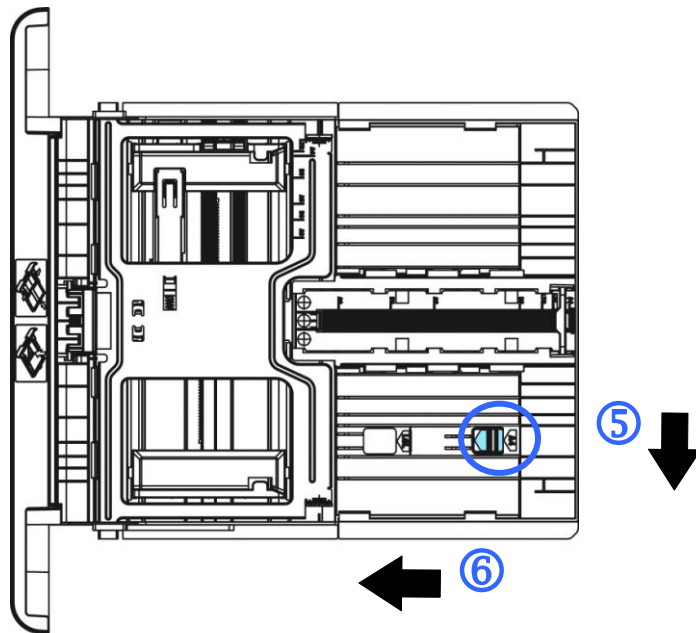

To move the tray back to the original A4 length, press down the length adjustment latch (7), and at the same time slide the manual tray to the right (8).

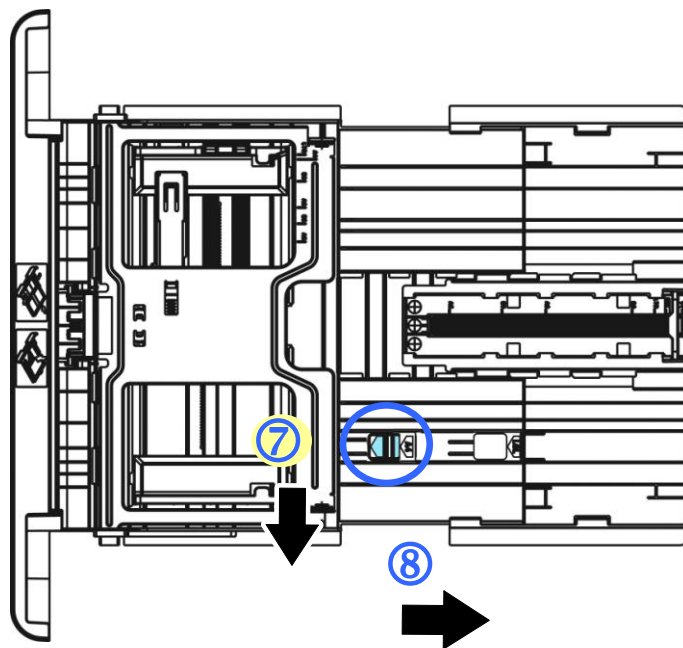

7. Load the paper stack with the **Printing Side FACE DOWN** as illustrated.

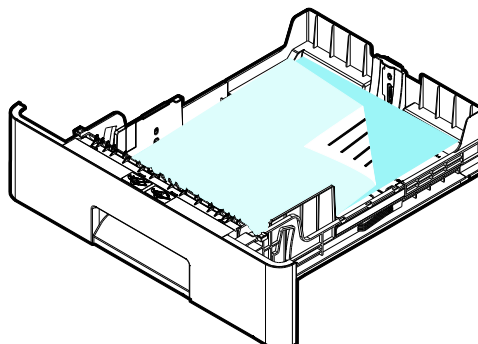

8. Insert the tray to the printer.

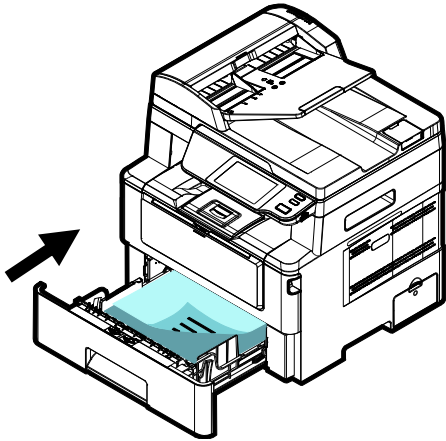

Note:



To avoid the chance of miss-fed, make sure the length guide tab and length slider are installed in their proper positions.

Make sure the end of your paper slightly touch the length guide as indicated in below.

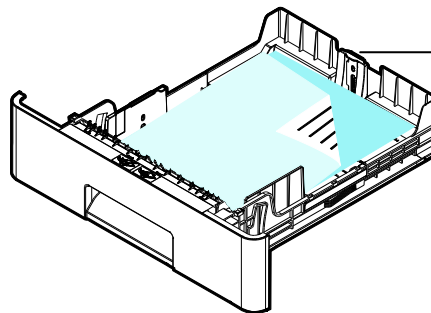

Length
Guide Tab

Paper sizes and weights used for Main Input Tray

Paper capacity	550 pages (70g/m ² plain paper)
Paper size	A4 (210 x 297 mm) A6 (105 x 148 mm) A5 (148 x 210 mm) B6 (125 x 176 mm) B5 (176 x 250 mm) Letter (216 x 279 mm) Legal (216 x 356 mm) Legal 13 (216 x 330 mm) Oficio (216 x 340 mm) Custom Size: 76 x 127 mm ~ 216 x 558 mm
Paper weight	60 ~ 120 g/m ²

* Duplex printing is available only for paper in Legal, Legal 13, Oficio, A4, B5, Custom Size (>B5), or Letter size.



Note:

- To ensure the best quality printing and copying, please use the paper or media which we have recommended.
- Make sure to fan your paper before loading it to the paper tray.
- If there are instructions about the printing side on the package of your paper, please follow the instructions to load your paper properly with the correct printing side to the paper tray.
- If the printing quality is not satisfactory or paper jams are easily to occur, turn over the paper stack so that the top page is now on bottom and then reload it to the paper tray.
- Pack and seal the remaining paper with the original packaging and store the paper in a dark and dry location away from the sunshine. Paper which collects much moisture is easy to cause jam during printing.

Loading Paper to the Manual Tray

When you need to print different size paper, you can use the manual tray.

1. Open the manual tray by grasping the handle and pull it down.

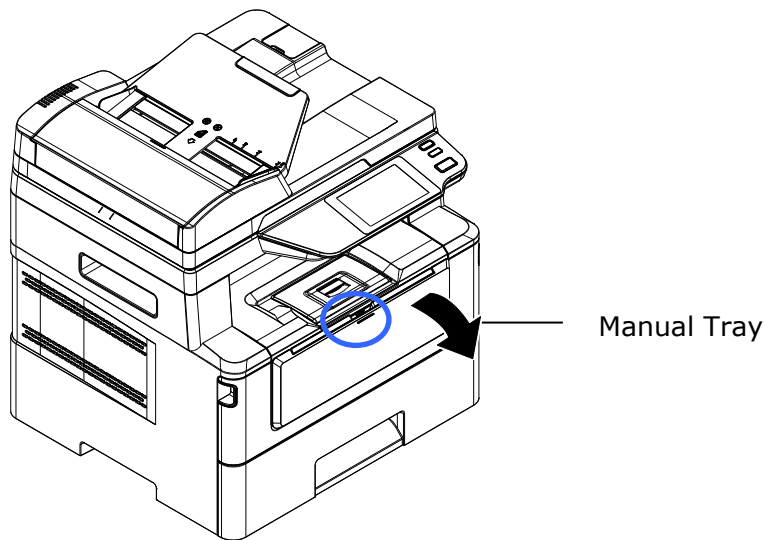

2. Pull out the manual tray extension to meet your paper size.

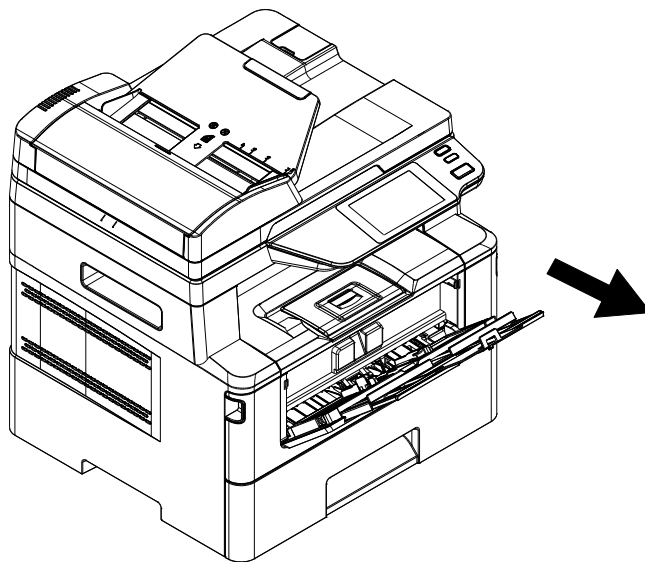

3. Fan your paper first to ensure that the pages do not stick together.

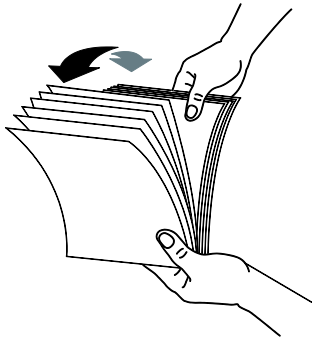

4. Align the edges of the documents by tapping the bottom of the stack against the table top. Rotate the stack 90 degrees and repeat.

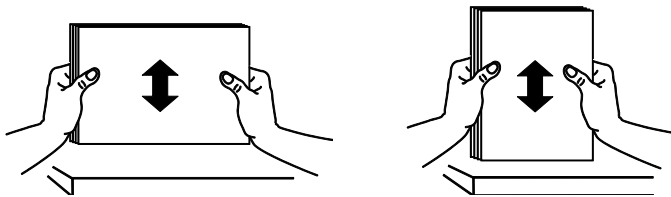

5. Load the paper stack with the **Printing Side FACE UP** as illustrated.

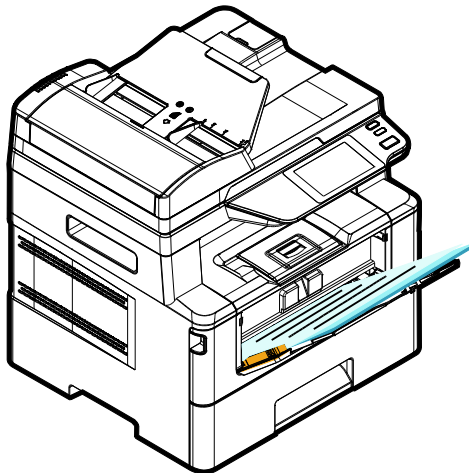

6. Slide the paper guides so that they slightly touch the paper stack.

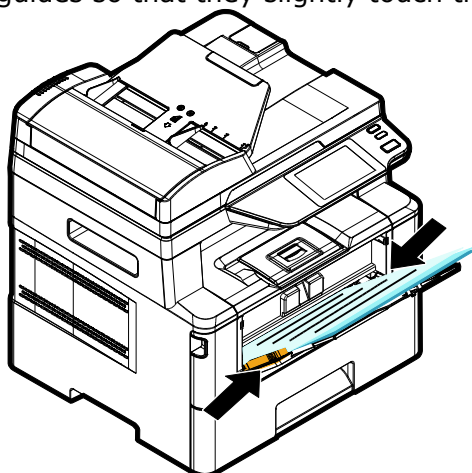

Paper sizes and weights used for Manual Tray

Paper capacity	10 pages (70g/m ² plain paper)
Paper size	A4 (210 x 297 mm) A5 (149 x 210 mm) A6 (105 x 149 mm) B5 (JIS) (182 x 257 mm) B6 (JIS) (125 x 176 mm) Letter (216 x 279 mm) Legal (216 x 356 mm) Legal 13 (216 x 330 mm) Oficio (216 x 340 mm) Custom Size: 76.2 x 127 mm ~ 216 x 558 mm
Paper weight	60 ~ 163 g/m ² (10 pages) 60 ~ 200 g/m ² (1 page)

* Duplex printing is available only for paper in Legal, Legal 13, Oficio, A4, B5 (JIS), Custom Size (>B5) or letter size.



Note:

- To ensure the best quality printing and copying, please use the paper or media which we have recommended.
- Make sure to fan your paper before loading it to the paper tray.
- If there are instructions about the printing side on the package of your paper, please follow the instructions to load your paper properly with the correct printing side to the paper tray.
- If the printing quality is not satisfactory or paper jams are easily to occur, turn over the paper stack so that the top page is now on bottom and then reload it to the paper tray.
- Pack and seal the remaining paper with the original packaging and store the paper in a dark and dry location away from the sunshine. Paper which collects much moisture is easy to cause jam during printing.

Connecting to Power

1. Connect the small end of the power cable to the power jack of your product.
2. Connect the other end to an appropriate power outlet.

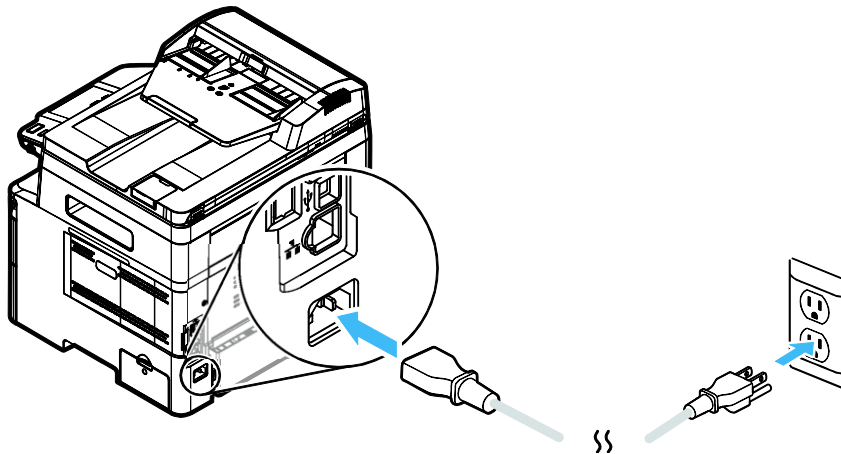

Turning on the Machine

To turn on the product, press the Power button  on the control panel, the LED light will turn solidly on. To turn off the product, hold and press the Power button for three seconds, the LED light will be off.

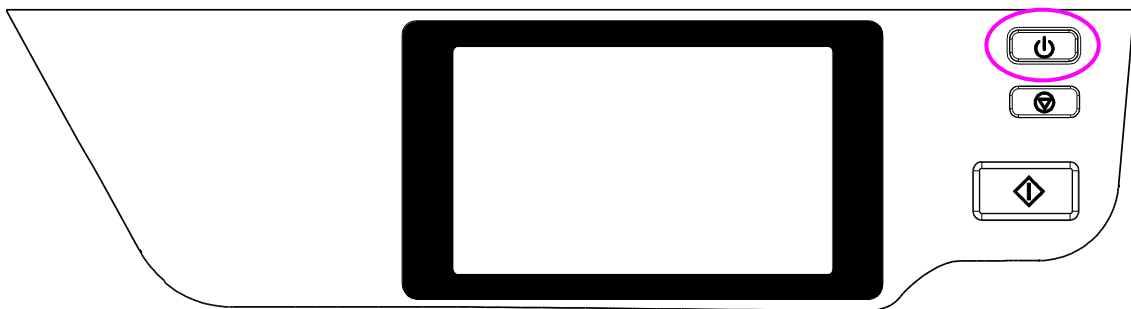

Note:

When the product is not in use, be sure to turn off the product to get a zero power consumption state.

Connecting to a Wired Network

1. Connect one end of your network cable to an available port of your Ethernet Hub.



2. Connect the other end to the LAN port at the back of the product as shown.

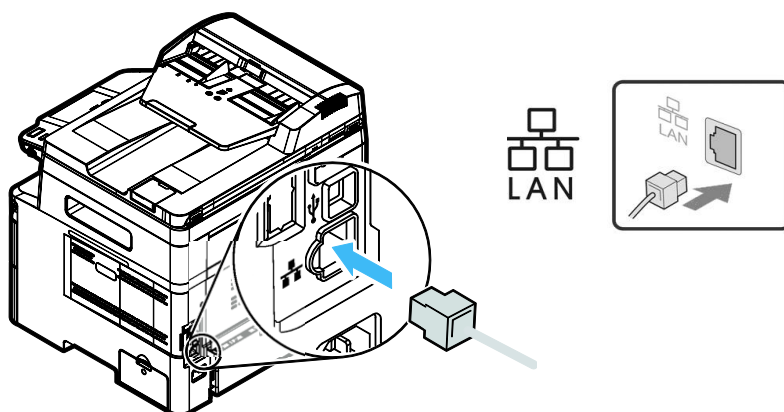

Checking the Product's Default IP Address

If the product has been connected to a network through a Ethernet cable, after turning on, an IP address will be automatically given by default through the DHCP server. Follow these steps to check the product's IP address:

To check the product's IP address,

1. Turn on the product by pressing the Power button.

2. Tap the [**Setting**] button  on main screen and then choose [**Show Machine Status**]. The following [**Show Machine Status**] screen will be prompted.

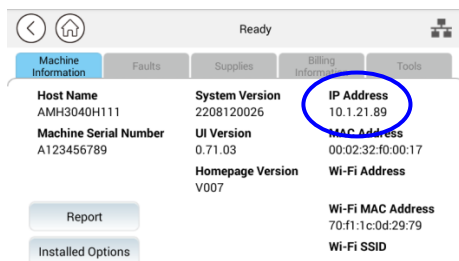
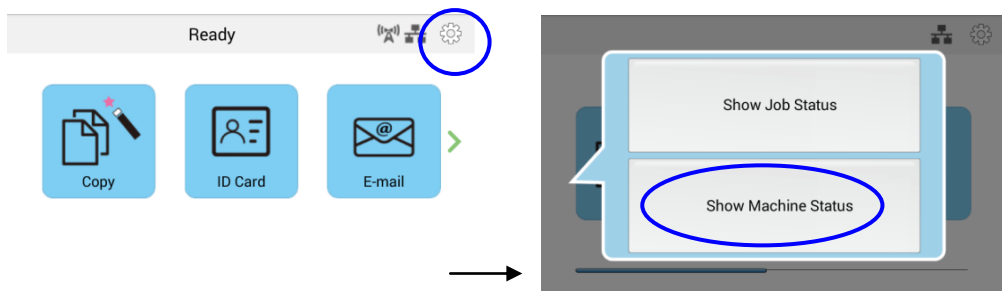

3. The system information including the IP address from the DHCP server will be prompted. For example, 10.1.21.89.

Specifying the Product's Date and Time

To set the product's date and time,

1. Tap the **[More Setting]** button on main screen and then choose **Show Machine Status>Tools>Device Settings>Date and Time** in succession.

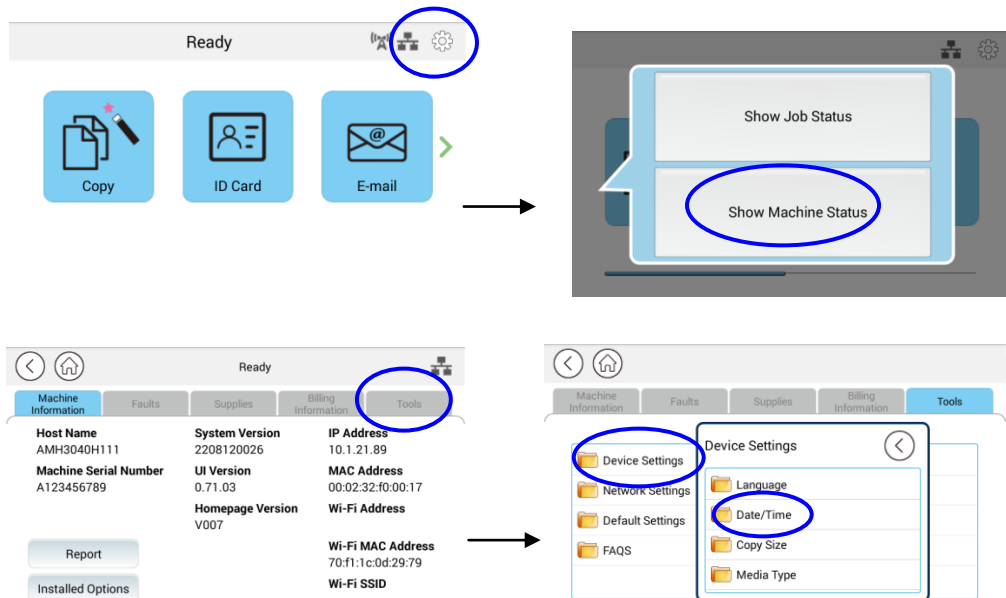

2. Choose current date and time on the **[Date]** and **[Time]** page. For example, enter **[2015-11-21]** (yyyy-mm-dd, year-month-date) as current date. Enter **[08:25]** (hr:min, hour:minute) as current time.

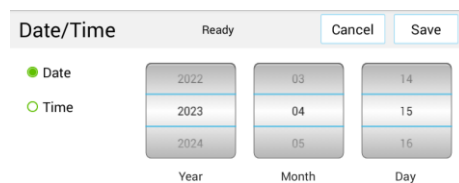

4. Click **[Save]** to save the setting and exit the page.

Specifying the Product's SMTP Server

To use the scan-to-email feature, you must specify the product's SMTP server.

To specify the SMTP server,

1. Tap the [**More Setting**] button on main screen and then choose **Show Machine Status>Tools>Network Settings>SMTP** in succession.

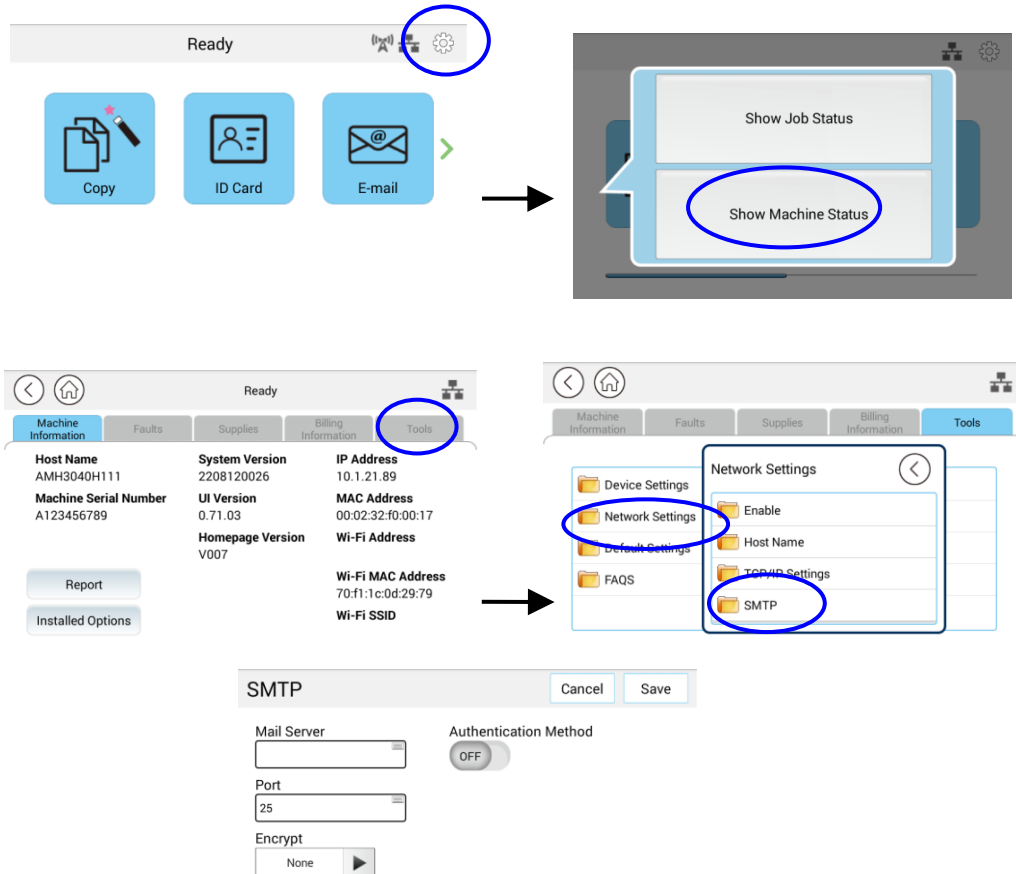

2. Enter your IP address for the SMTP server and the authentication information if required.

E-mail Server Setting	
Mail Server	Enter the IP address of your SMTP server.
Port #	Enter the port number of the SMTP server. * 25
Authentication Method	Enter the email authentication method. Choice: *Off, On
Encript	Choose your Encripton method. Choice: TLS/STARTTLS, SSL
Login Name	Enter the login name for SMTP authentication.
Password	Enter the password for SMTP authentication.

3. Click [**Save**] to save the setting and exit the page.



Note:

1. Please check the SMTP server information with your Network Administrator.
2. The login name is case-sensitive and is up to 32 digits or characters.
3. The password is case-sensitive and is up to 16 characters.

Specifying the Product's Filing Server

The product allows you to scan and save the scanned image to a specified destination including FTP and SMB server on the network, or a USB flash drive.

Before sending the image files to FTP or SMB server on the network, you need to first setup the FTP or SMB destination through the embedded web page. Please follow these steps to create a FTP or SMB destination.

To set FTP or SMB as your filing destination

1. Open your browser and enter the product's IP address on the URL address. This will prompt the product's webpage.
2. On the product's web page, choose [**Properties**] and then choose [**FTP/SMB Setup**] on the left side. The following [**File Destination**] page will be displayed.

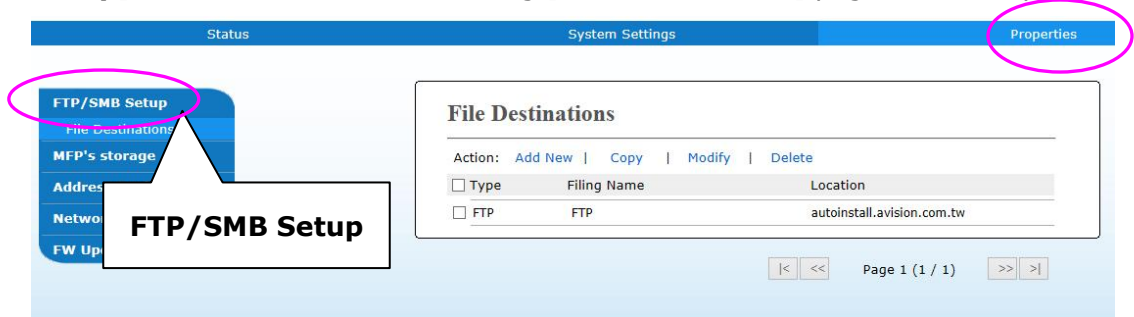

3. Choose [**Add New**] to prompt the [**New Filing Settings**] page.

4. Refer to the following table to enter proper settings.

Item	Description
Filing Name (Name of Destination)	Enter the name of the destination. (The name will be displayed in the destination list.)
Protocol	Choose type of protocol. Choice: SMB, FTP, FTPS
URL (Address)	Enter the domain name or IP address for the server. For example, domainname.com\foldername or 10.1.23.145\foldername.

Port	Enter the port number of the server here if your port number is different with the default setting. Default: FTP :21, SMB:139, FTPS: 990
Login Name	Enter the authorized login name to the server.
Password	Enter your password to the server.
Retype Password	Reenter your password.

5. After completing entering the settings, click [**Submit**] to finish. The new filing destination will be displayed in the destination list. This means you have successfully created a new SMB or FTP filing destination.

Creating Your Address Book

The product allows you to scan and save the scanned image to your recipients via e-mail or fax. Yet before sending the image files to e-mail or fax, you need to first setup address book through the embedded web page. Please follow these steps to create your address book.

To create your address book

1. Open your browser and enter the product's IP address on the URL address. This will prompt the product's webpage.
2. On the product's web page, choose [**Properties**] and then choose [**Address Book**] on the left side. The following page will be displayed.

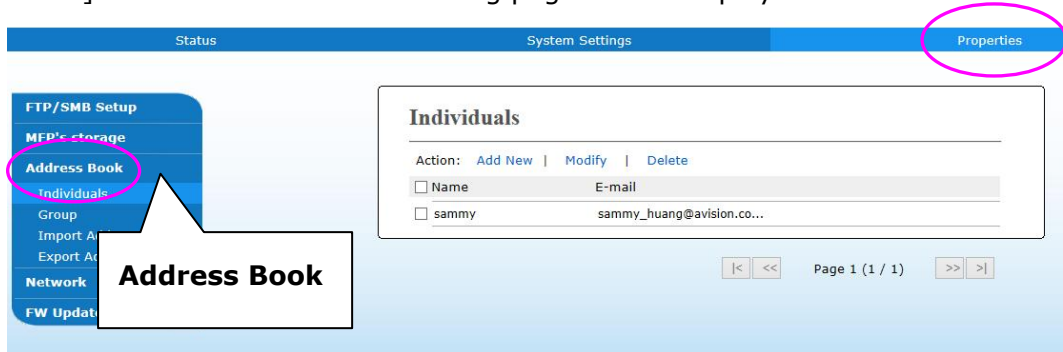

3. Choose [**Add New**] to enter the name, and e-mail address for an individual recipient.
4. After completing entering the settings, click [**Apply**] to finish. The new recipient will be displayed in the e-mail list. This means you have successfully created an address book.

Installing the Driver

System Requirement

Windows 7, Windows 8, Windows 10, Windows 11

For USB Interface Users

Please follow these steps to install the scanner, and printer drivers if this machine is connected to your computer via a USB cable.



Important!

DO NOT connect the USB cable before installing the scanner, printer drivers.

1. Insert the supplied CD into your CD-ROM drive. The installation menu will be displayed.
2. To install the **scanner /printer** drivers:

Click 「**Install Scanner Driver and Printer Driver**」 and follow the on-screen instructions to complete the installation of the program.
3. When the [**Setup Type**] dialog box appears, select [**USB**] and then click [**Next**].

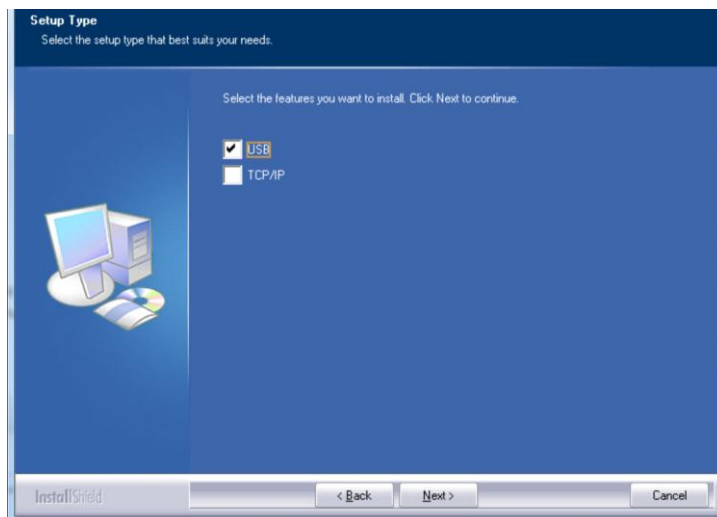

4. During installation, the [**USB Connection**] dialog box will be prompted to instruct you to turn on the MFP and then connect the MFP to your computer with a USB cable.
 - a. Connect one end of the USB cable to your computer.
 - b. Connect the other end to the USB port of your product.

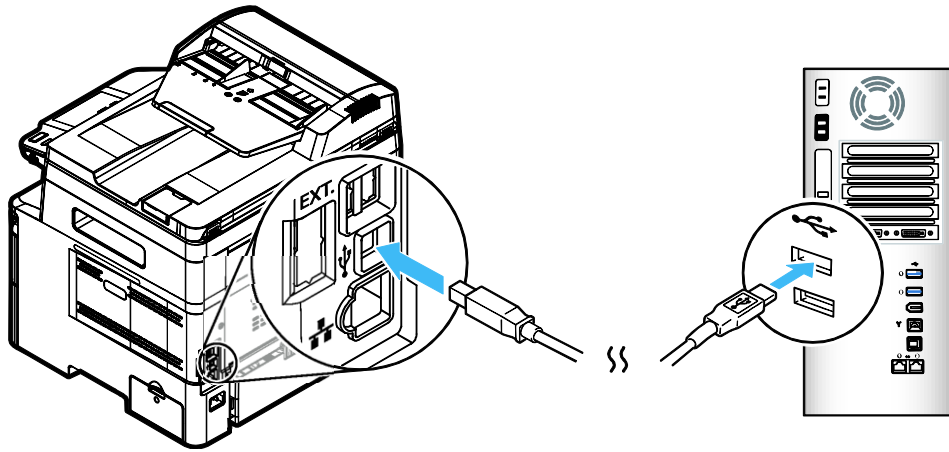

5. When 「**Found New Hardware**」 screen appears, click **Next** and follow the on-screen instruction to complete the installation.
6. When the following dialog box appears, click [**Yes**] if you wish to create a desktop shortcut for the scanning software Capture Tool.

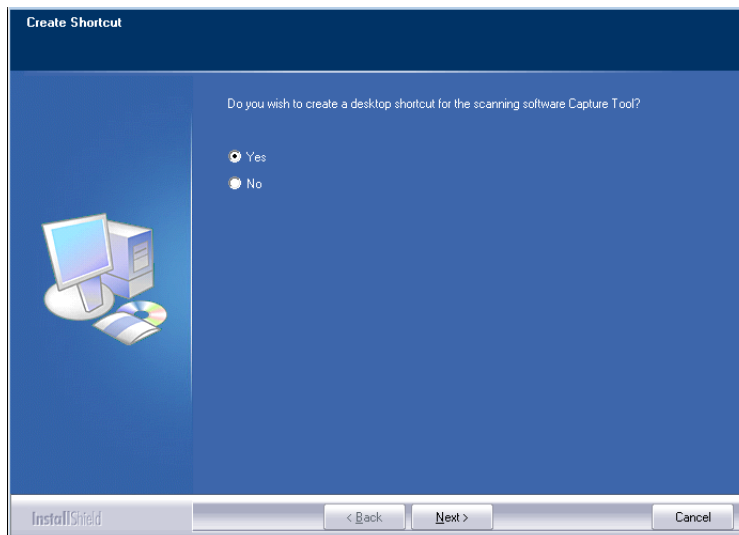

7. When the **Finish** dialog box appears, click **Finish** to complete.

If you have successfully installed the printer's driver, you will find a printer, 「AM40XX MFP」, has been added in the 「Printers and Faxes」 option from the Control Panel.

For Network Interface Users

Please follow these steps to install the scanner, printer drivers if this machine is connected to your computer via a network.

1. Insert the supplied CD into your CD-ROM drive. The installation menu will be displayed.
2. To install the scanner driver and printer driver:
Click 「**Install Scanner Driver and Printer Driver**」 and follow the on-screen instructions to complete the installation of the program.
3. When the **Setup Type** dialog box appears, check [**TCP/IP**] and click [**Next**] to continue.

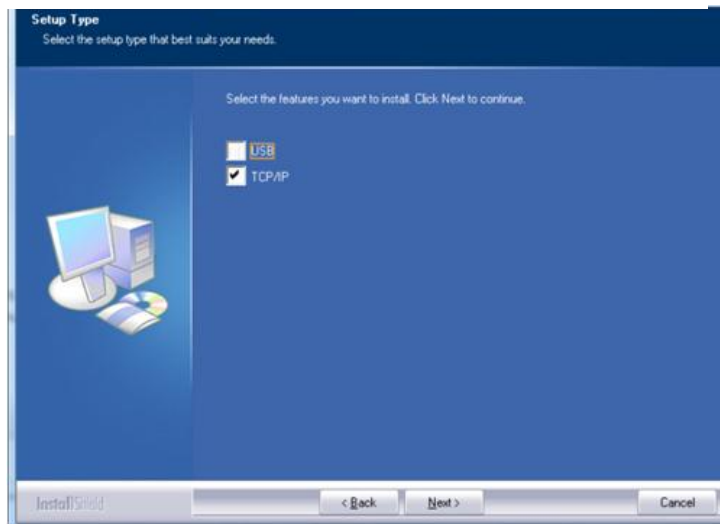

4. When the following **Set IP** dialog box appears, choose one of the following options and click [**>**] to add to the printer list. When the desired option setting is completed, click [**OK**]. (Follow the preceding section – Checking the Product's Default IP Address to obtain the product's default IP address.

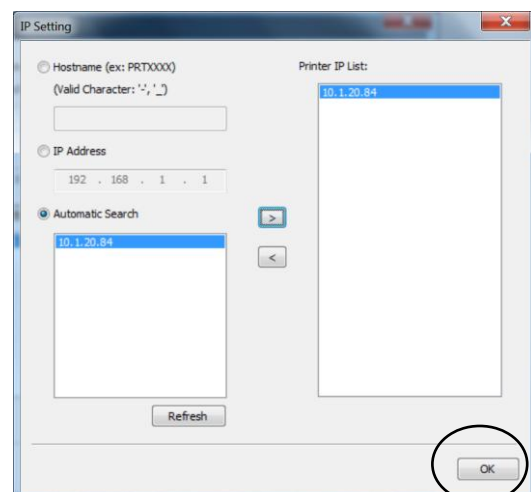
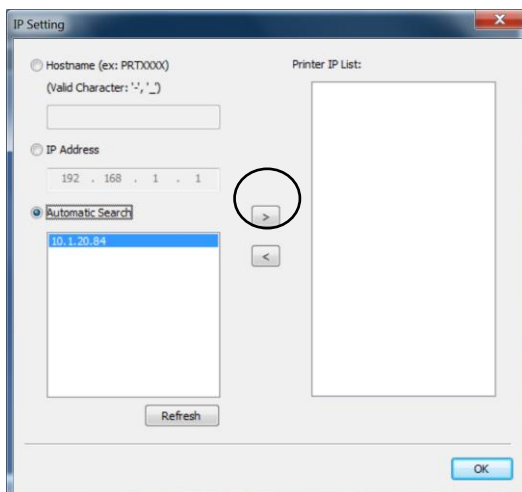

Host Name	Enter the product's host name to be connected in the blank box of the Host Name option.
IP Address	Enter the product's IP address to be connected in the blank box of the IP Address option.
Auto Search	Searches the product's printers automatically, and all the product's host names found in the network will be displayed in the box of the Automatic Search. Use your mouse to choose your desired host name to be connected.

5. When the following dialog box appears, click [**Yes**] if you wish to create a desktop shortcut for the scanning software Capture Tool.

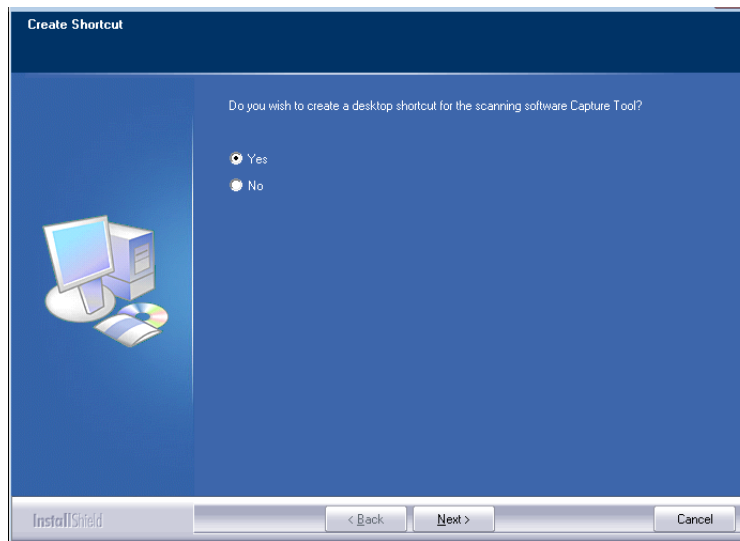

6. When the Finish dialog box appears, choose 「**Finish**」 to complete.
If you have successfully installed the printer's driver, you will find a printer, 「AM40XX NetWork」, has been added in the 「Printers and Faxes」 option from the Control Panel.

Uninstalling the Scanner Driver and Printer Driver

1. From the 「**Start**」 menu, select 「**All Programs**」, 「**the AM40XX MFP**」, and then 「**Uninstall Driver**」.
Or from the 「**Start**」 menu, select 「**Control Panel**」, 「**Add or Remove Programs**」, 「**the AM40XX MFP**」, and then 「**Remove**」.
2. Follow the instructions on the screen to complete removing the scanner driver and the printer driver.

3. Setting up and Managing Destinations

This section provides procedure for the administrator to setup and manage your destinations including e-mail addresses or network folders to distribute the scanned document on the network.

Setting up Your Address Book

This section provides procedure for the administrator on how to setup Address Book.

Adding a New Member

To add a new member,

1. Open your browser.
2. Type the product's IP address on the URL field of your browser. For example, 10.1.21.71. The following embedded web page will be displayed

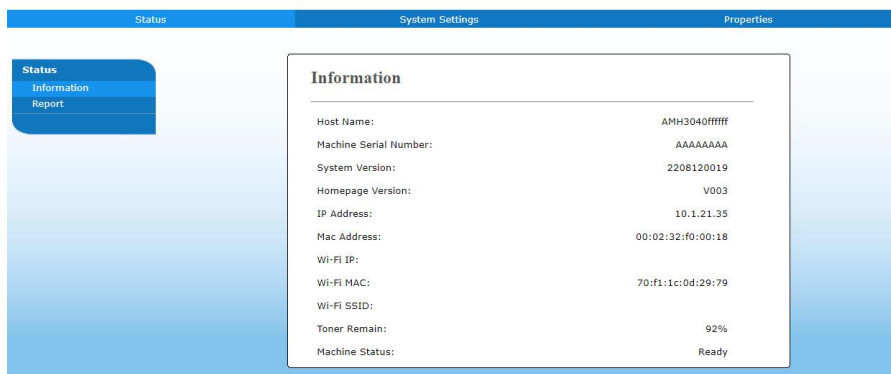

3. On the product's web page, choose [**Properties**] and then choose [**Address Book**] on the left side. The following [**Address Book**] page will be displayed.



4. Choose [**Add New**] and enter the name, and e-mail address for an individual recipient.
5. After completing entering the settings, click [**Apply**] to finish. The new recipient will be displayed in the e-mail list. This means you have successfully created an address book.

Modifying a Current Member

To modify a current member,

1. Repeat Step 1 to Step 4 from the previous section, *Adding a New Member*. The [**Address Book**] page appears.
2. Choose the member you want to modify from the list and then choose [**Modify**] to prompt the [**Modify Member**] page.
3. Modify your member information. Click [**Submit**] to save the setting or [**Cancel**] to leave the page without saving any setting.

Deleting a Current Member

To delete a current member,

1. Repeat Step 1 to Step 4 from the previous section, *Adding a New Member*. The [**Address Book**] page appears.
2. Choose the address you want to delete from the list and then choose [**Delete**] to erase the address. A Confirmation dialog box appears to confirm your deletion. Click [**OK**] to confirm or [**Cancel**] to exit.

Adding a New Group

To send multiple recipients simultaneously at one time, you can create groups to speed up the process. Up to 5 members can be included in one group and a total of 10 groups can be created.

Follow these steps to create a new group,

1. Repeat Step 1 to Step 4 from the previous section, *Adding a New Member*. The [**Address Book**] page appears.
2. Click [**Group**] and then choose [**New**] to prompt the [**Add a New Group**] page.
3. Enter your group name.
4. Choose the address from the right side and click ← to add a member to the group.
5. Click [**Apply**] to save the setting or [**Cancel**] to leave the page without saving any setting.

Modifying a Current Group

To modify a current e-mail group,

1. Repeat Step 1 to Step 4 from the previous section, *Adding a New Member*. The [**Address Book**] page appears.
2. Click [**Group**] and choose the group you want to modify from the list and then choose [**Modify**] to prompt the [**Modify Group**] page.
3. Modify your group information. Choose the group member you wish to add and then click ← to add the new member or click → to delete an old member from the group.
4. Click [**Apply**] to save the setting or [**Cancel**] to leave the page without saving any setting.

Deleting a Current Group

To delete a current e-mail group,

1. Repeat Step 1 to Step 4 from the previous section, *Adding a New Member*. The [**Address Book**] page appears.
2. Click [**Group**] and choose the group you want to delete from the list and then choose [**Delete**] to erase the group. A Confirmation dialog box appears to confirm your deletion. Click [**OK**] to confirm or [**Cancel**] to exit.

Importing External Address Book

The product allows you to import external address book from other devices in a .csv format to save your time in typing all the addresses. Before importing external address book to this product, be sure an address book file in .csv format has been created in advance.

To import current address book,

1. Repeat Step 1 to Step 4 from the previous section, *Adding a New Member*. The [**Address Book**] page appears.
2. Click [**Import Address Book**] to prompt the [**Import Address Book**] page.
3. Click [**Browse**] to search the address book file on your computer.
4. Click [**Import**] to start importing the address book file. In a second, the imported address book will be added in the product.

Exporting Current Address Book

The product allows you to export current address book of this device to another device in a .csv file format.

To export current address book,

1. Repeat Step 1 to Step 4 from the previous section, *Adding a New Member*. The [**Address Book**] page appears.
2. Click [**Export Address Book**] to prompt the [**Export Address Book**] page.
3. Click [**Export**] and then [**Browse**] to specify the location of your address book.
4. Click [**Apply**] and the current address book will be stored in a .csv file.

Setting up Your File Destinations

The section provides procedure on how to setup your file destinations to send your scanned document to a specified network folder.

Adding a New File Destination

To create a new file destination, follow these steps:

1. On the product's web page, choose [**Properties**] > [**FTP/SMB Setup**] and then [**Add New**] to prompt the [**New File Destination**] page.

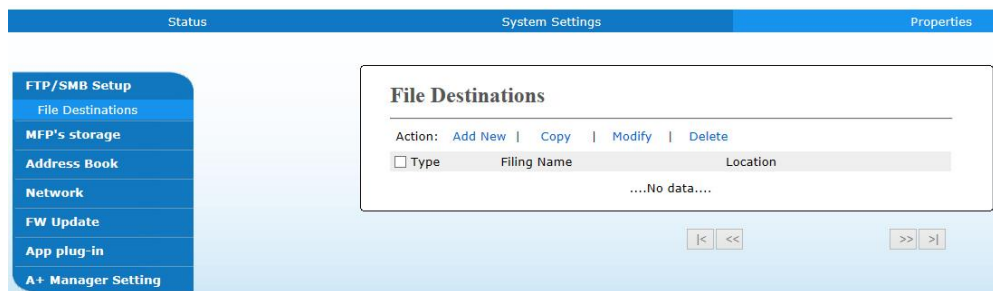

Enter the following information respectively:

Item	Description
Destination Name	Enter the name of your destination. The name will be shown in the LCD screen.
Protocol	Enter the type of protocol of your destination server. Choice: FTP, SMB
URL	Enter the IP address and the shared folder name of your FTP server.
Port #	Enter the port number of the destination server. * 21 (FTP), 139 (SMB)
Login Name	Enter the user name of the destination server.
Password	Enter the password of destination server.
Retype Password	Choose your desired scan option profile.

2. Click [**Submit**] to save the setting or [**Cancel**] to leave the page without saving any setting.

Modifying a Current File Destination

To modify a current file destination,

1. Repeat Step 1 to Step 2 from the previous section, *Adding a New File Destination*. The [**New File Destination**] page appears.
2. Choose the destination you want to modify from the list and then choose [**Modify**] to prompt the [**Modify File Destination**] page.
3. Modify your destination information.
4. Click [**Submit**] to save the setting or [**Cancel**] to leave the page without saving any setting.

Deleting a Current File Destination

To delete a current file destination,

1. Repeat Step 1 to Step 2 from the previous section, *Adding a New File Destination*. The [**New File Destination**] page appears.
2. Choose the destination you want to delete from the list and then choose [**Delete**] to erase the destination. A Confirmation dialog box appears to confirm your deletion. Click [**OK**] to confirm or [**Cancel**] to exit.

4. Operation

Loading Paper

The product can scan and send document(s) either in the ADF (Automatic Document Feeder) or on the glass. If you need to send multiple pages, please load your papers in the ADF. The ADF can hold up to 75 pages (70 g/m², 20 lbs) at one time. If you need to send pages from books, newspaper clippings, or paper with wrinkles or curls, please place your paper on the glass.

Notice on Using the ADF

Before using the ADF, please make sure that your paper meets the following specifications:

- Document(s) can range in size from 76.2 x 127 mm (3 x 5 in.) to 216 x 356 mm (8.5 x 14 in.).
- Document(s) should be square or rectangular and in good condition (not fragile or worn).
- Document(s) should be free of curl, wrinkle, tears, wet ink, or punch holes.
- Document(s) should be free of staples, paper clips, paper sticky notes.
- Keep the glass clean without document placed on it.

**Note:**

To transmit irregular types of document(s), place the document(s) on the glass or make a copy first and then transmit the copy instead.

Placing Document(s) in the ADF

Fanning Your Document

Note:

To avoid occasional multi-feeds or paper jams, please fan your documents and align the top edges before feeding them into the scanner.

1. Make sure your document is free of staples, paper clips and is not torn out.
2. If you have multiple pages, fan your document(s) to avoid occasional paper jam.

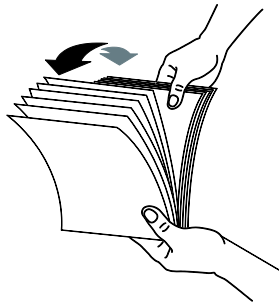

3. Rotate the documents by 90 degrees and fan them in the same manner.
4. Align the edges of the documents in a step-like pattern (see picture below).

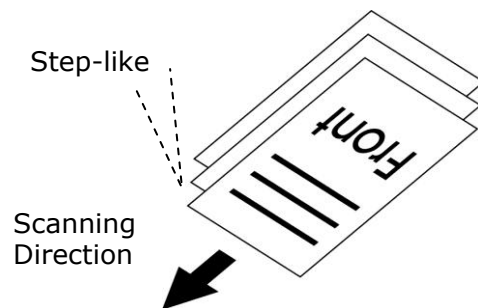

5. Align the edge of document against the Paper Guides and make sure the First Page feeds in first.

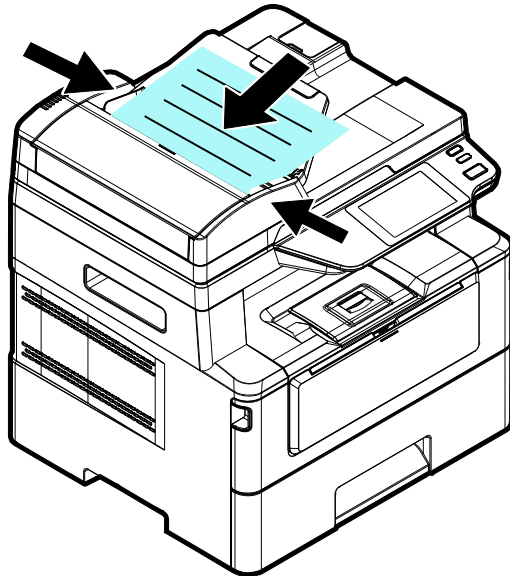

Note:

It is all right if the document is loaded to the feeder with a slight angle as shown in below. The product is designed with the auto crop and deskew function, therefore, the image can be automatically cropped and straightened.

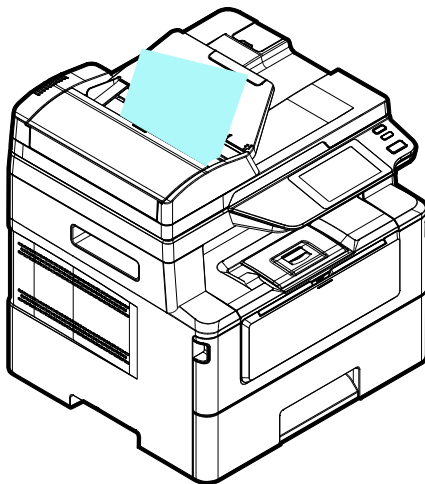

Placing Document(s) on the Glass

1. Open the document(s) cover to reveal the glass.
2. Place your document with the text **FACE DOWN** on the glass and align the document in the upper-left corner.

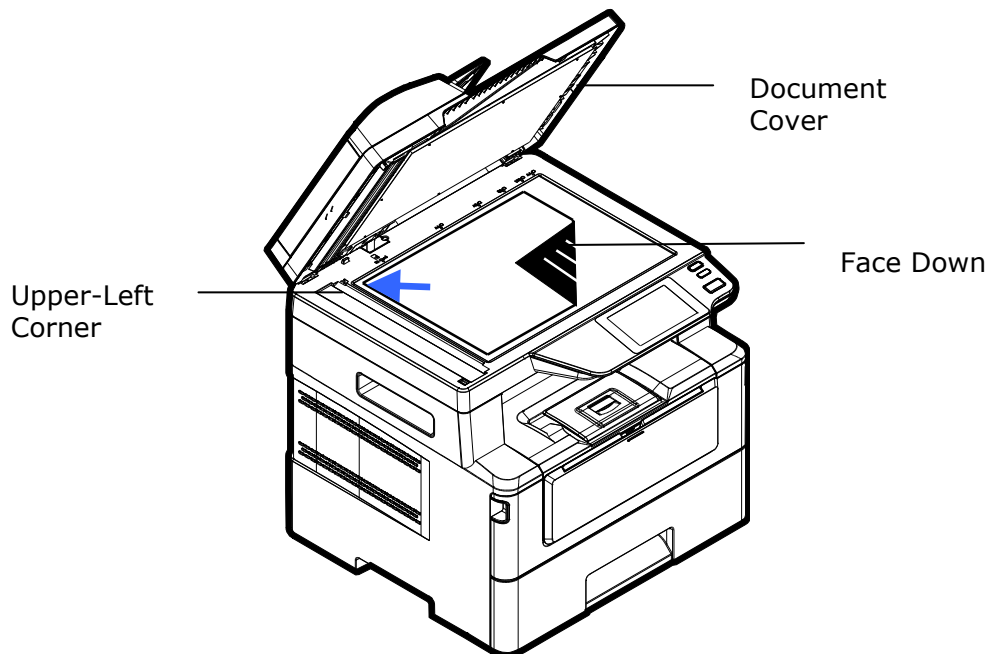

3. Close the document cover.

Paper Orientation

Place your A4 or LTR paper vertically on the glass with the text facing down and align it with the A4 or LTR marks.

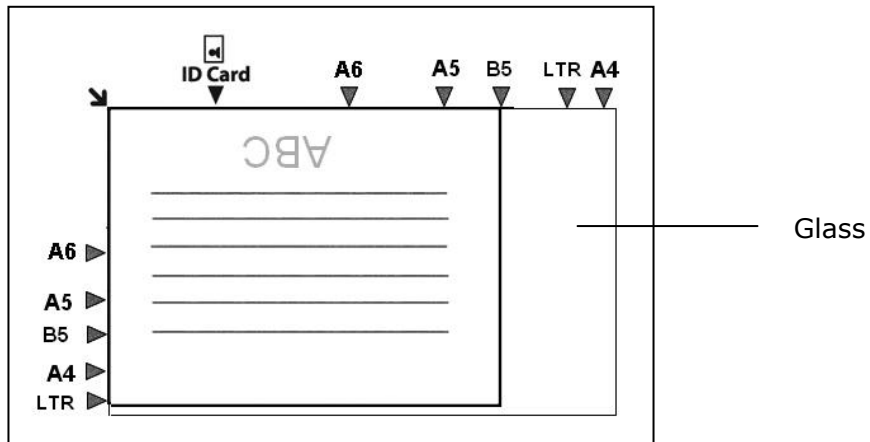

Copy

Using Auto Document Feeder

Copying 1-Sided Document

1. Make sure the [**Copy**] is displayed on the screen. If not, tap [**Copy**] on the home screen.

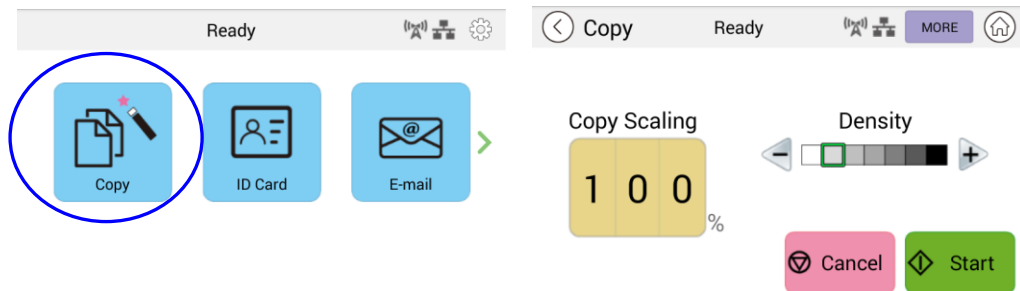

2. Load document into the feeder. No need to worry about facing down or facing up since the Intelligent Copy System will automatically make a correct and perfect copy.



Note:

The product is built-in with the state-of-the-art image processor to provide an optimal default settings and image quality for common copy job. Change the default copy settings only when you need to perform an unusual copy task.

3. The product will automatically make one copy of your document and then the following screen will be prompted enquiring if more copies is needed.



- a. If no more copies are required, press  (Back) to return to the main Copy screen.
- b. Enter your copy count and press [**Start**] to complete.

Copying 2-Sided Document

1. Make sure the [**Copy**] (Intelligent Copy) is displayed on the screen. If not, tap [**Copy**] on the home screen.

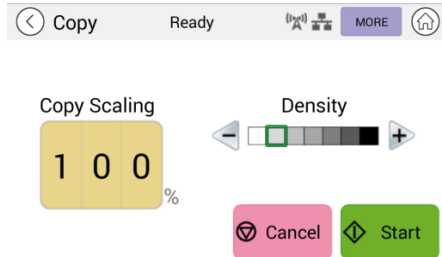

2. Load a stack of multi-page document to the feeder. The product will first automatically scan first page and the following preview screen will be displayed.

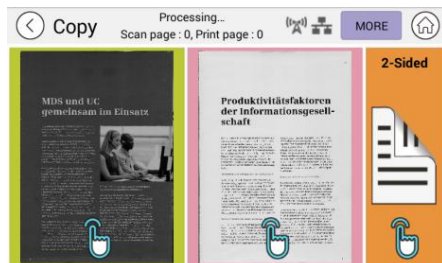

- (1) If you need to make 2-Side copy, press [**Scan 2-Sided**].
- (2) If you need to make 1-side copy, choose your desired page.

3. The product will continue the copy of the rest document.



Note:

Since the product detect only the first page, therefore, the document arrangement (such as odd page face up...) of the whole stack of documents must be consistent with the first page.

[More...] Button

- (1) Click [**More**] to access more copy options.

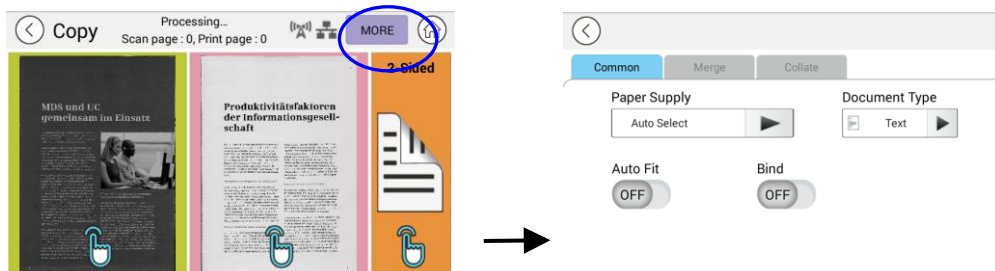

- (2) Change your copy settings and then press [**<**] to return to the main page.
- (3) Choose one side or 2 sides, then the copy will begin.

Flatbed Copy

1. Make your document with text **FACE DOWN** on the document glass.
2. Make sure the [**Copy**] (Intelligent Copy) is displayed on the screen. If not, tap [**Copy**] on the home screen.

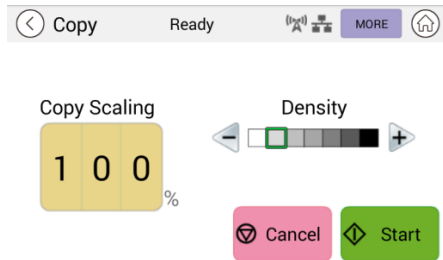

Confirm or change Copy options as desired such as Scaling, Density.

3. Press  to complete.

Basic Copy Settings:

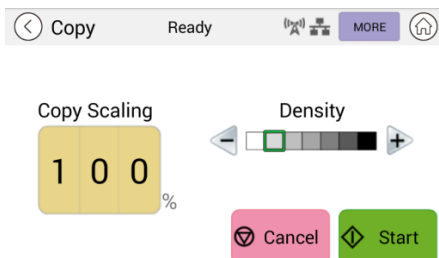

Copy Scaling	Choose if you wish to reduce or enlarge your original. Range: 25~400% (*100%)
Density	Lighten or darken your original. Levels: 1~7 ((default: 2 (text mode); 3 (mixed mode))

* **Default settings is shown in italic bold style**

More Copy Settings

Click [**More**] to access more copy settings.

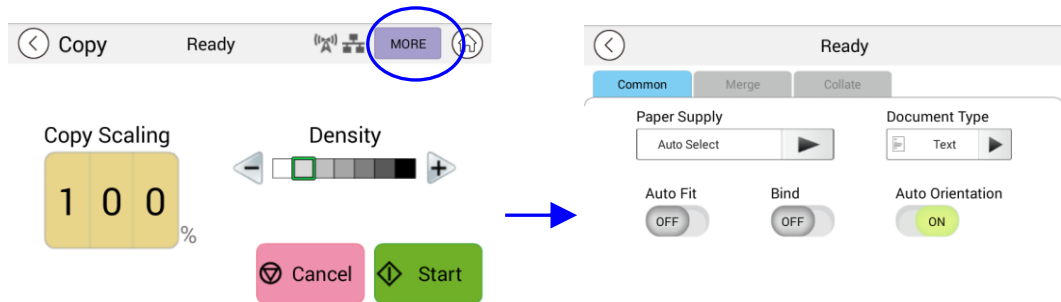

Common Settings:

Paper Supply	Choice: <i>Auto Select</i> , Tray 1, Manual. Auto Select automatically helps a user find the input tray that best meets the scanning paper size.
Document Type	Chooses your copy mode. Choice: <i>Text</i> /Mixed Text: Select to sharpen your text. Mixed: Suitable for most typed originals.
Auto Fit	Check this option to automatically reduce or enlarge your original according to output paper.
Bind	The Bind feature allows you to scan and combine separate documents continuously at the same scan settings. If the [Bind] feature is turned on, after your first scan is finished, a dialog box will be prompted to ask you if you wish to continue scan. If you wish to continue scan, place your document on the flatbed and then tap [Scan] button to combine your scan. Tap the [Finish] button to end your scan and the dialog box will not be prompted again. Choice: On/ <i>Off</i>
Auto Orientation	Choose if you wish to enable the function of automatically detecting the orientation of the original document. Choice: Off/ <i>On</i>

* The default setting to be displayed in italic bold style

Using the [Bind] Feature



Important:

The 「Bind」 feature is only available for flatbed copy.

When the [**Bind**] feature is turned on, copy for the 1st sheet of document will be completed first. Then the following screen will be prompted indicating that the next sheet or stack of document is ready to be placed.

>> To end your job, tap 「**Finish**」.

>> To copy next sheet, open the document cover to remove first sheet and then place next sheet on the glass, tap [**Continue**] to complete your copy; or place your next stack of document in the document feeder and then tap [**Continue**] to complete.

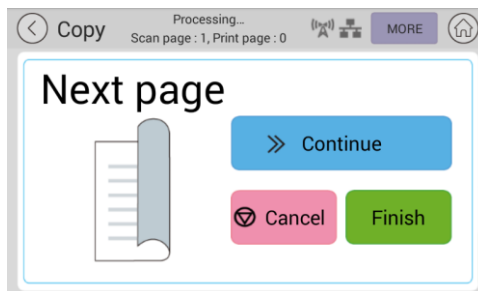

Merge Settings

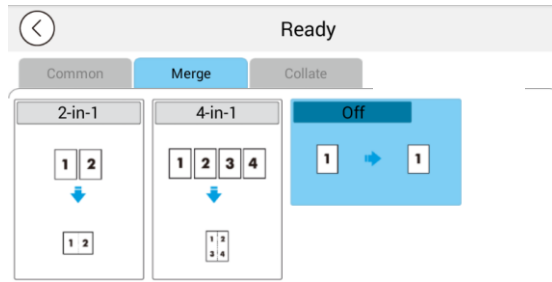

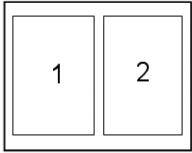
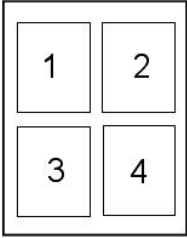
2-in-1	<p>Combine 2 pages of your document and copy them onto a single sheet of paper.</p> 
4-in-1	<p>Combine 2 pages of your document and copy them onto a single sheet of paper.</p> 
<i>off</i>	Do not combine your pages.

* **The default setting to be displayed in italic bold style**

Collate Settings

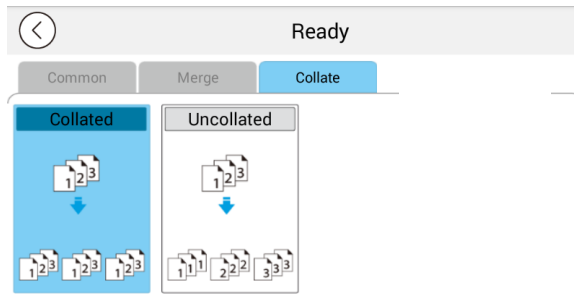

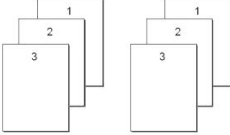
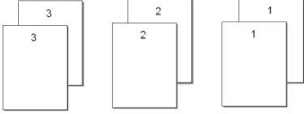
<p>Collated:</p>	<p>Choose your copies to be placed in "Sort" (e.g. pages 1,2,3/1,2,3/1,2,3) order.</p> 
<p><i>Uncollated:</i></p>	<p>Choose your copies to be placed in "Stack" (e.g. pages 1,1,1/2,2,2/3,3,3) order.</p> 

*** : Factory Default settings is displayed in italic bold style**

ID Card Copy

The product is designed with the auto crop and deskew feature which allow you to easily place your document on the glass platen without the need to carefully align your document to the starting point. Even though the document is placed with a slight angle as illustrated in below, the front side and rear side of your ID card can be copied perfectly on a single sheet of paper.

The Operation Steps:

1. Place one side of your ID card **FACE DOWN**, aligned with the 「ID Card」 mark as indicated below:

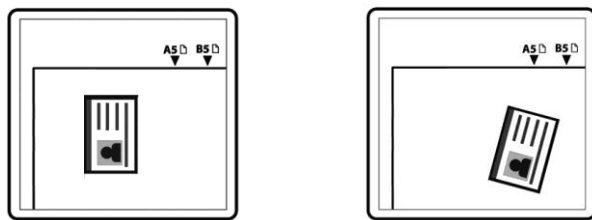

2. Tap the 「ID Card Copy」 button on the main screen, and the following 「ID Card Copy」 screen will be displayed.

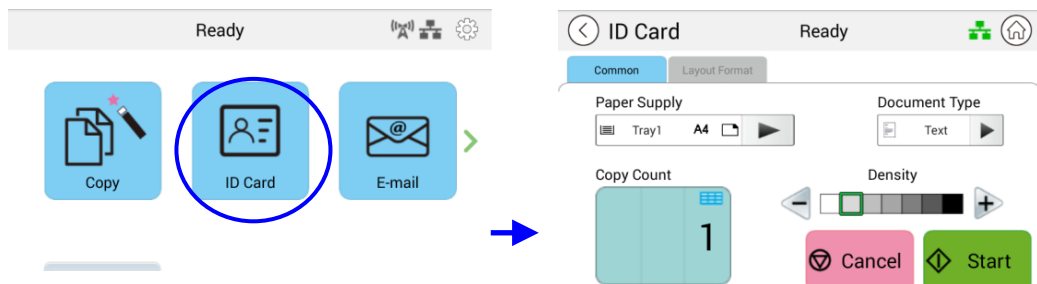

3. Confirm or change ID Card Copy options.
4. Enter your copy count with the Up ▲ /Down ▼ key.
5. Tap the 「Start」 button  on the touch panel to start copying your card.
6. After the first side scanning is finished, the 「Do you wish to continue?」 dialog box will be prompted.
7. Open the document cover and place the other side of your card, aligning it with the 「ID Card」 mark as illustrated.

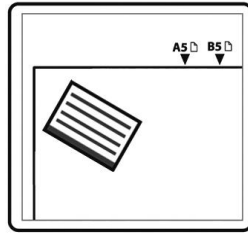
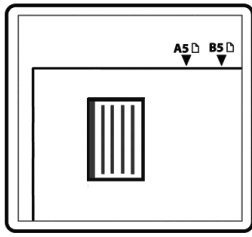

8. Tap 「**Yes**」 on the touch panel to continue scanning the other side of your card or tap 「**Cancel**」 to leave the screen. The result is illustrated in below:



Important!

The ID Card Copy feature does not support loading your cards from the auto document feeder.

「ID Card Copy」 Settings

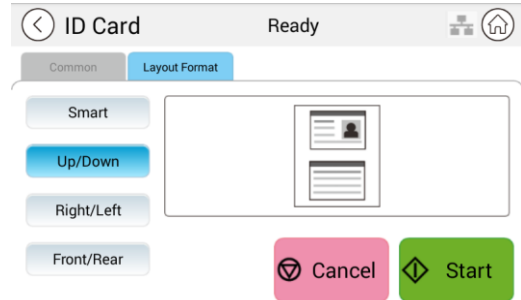
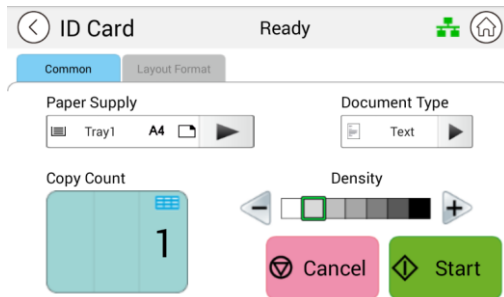

Common

Paper Supply:	Choose your paper supply. Choice: Auto Select , Tray 1, Manual Tray. Auto Select automatically helps a user find the input tray that best meets the desired paper size.
Document Type	Chooses your copy mode. Choice: Text /Mixed Text: Select to sharpen your text. Mixed: Suitable for most typed originals.
Density:	Lighten or darken your original. Levels: 1~7 (default: 2 (text mode); 3 (mixed mode))

Layout Format

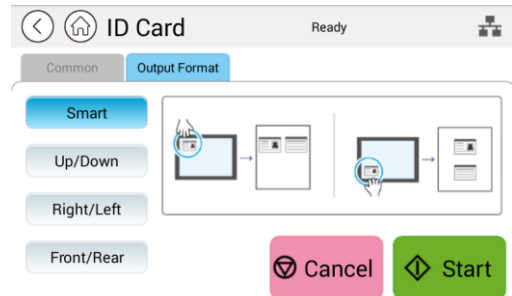
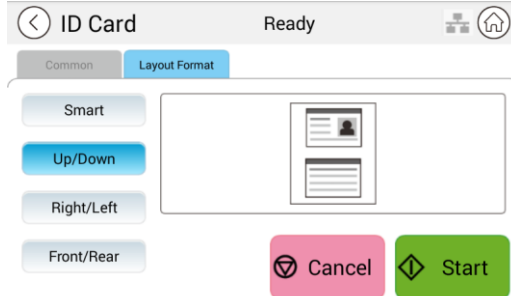

Smart

	When the 1 st side is placed in area A, no matter what position you place the 2 nd side, the output layout will be right and left.
	When the 1 st side is placed in area B, no matter what position you place the 2 nd side, the output layout will be up and down.

E-Mail

The 「**E-Mail**」 function allows you to scan your documents and send the scanned image to your recipients via e-mail.

The Operation Steps:

1. Place your multi-page document **Face Up** and **Top First** in the auto document feeder or single-page **Face Down** on the document glass.
2. Tap the 「**E-Mail**」 button on main page to prompt the 「**E-Mail**」 screen.

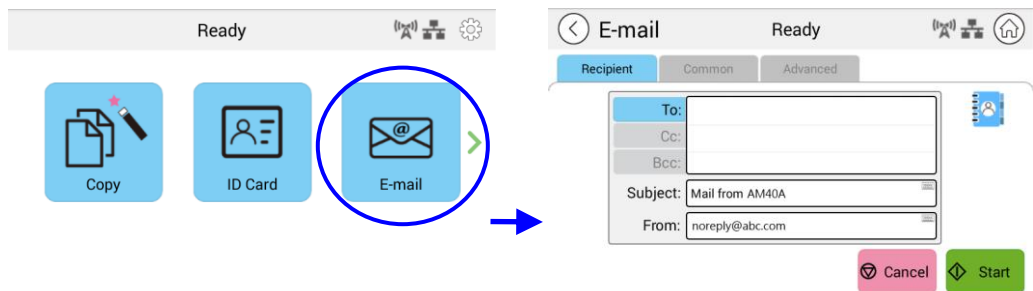

3. Tap the blank field of **To** option, and a soft keyboard screen appears. Enter your recipient's email address and press  to complete.

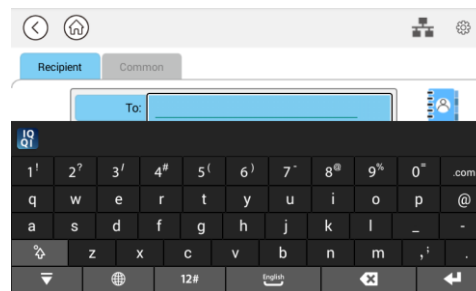

After completing entering the email address,  a recycle bin icon will be displayed at the right corner.



: Tapping the button allows you to instantly delete the current To addresses.

4. If necessary, tap the blank field of the 「**CC**」 and 「**BCC**」 option to enter the e-mail address of the rest recipients.
5. Tap the blank field of Subject option, enter the e-mail subject, and tap [OK] to confirm the subject.
6. Tap the blank field of From option, enter the sender's e-mail subject, and tap [OK] to complete.

Note: The sender's address is a must item you need to fill before sending the scanned image.

7. Tap 「**More**」/「**Advanced**」 to confirm or change E-mail options as desired such as Resolution, Output Color, Original, 1/2-Sided Scan, File Format. Also touch other tabs for more options.

Resolution:	Choose the resolution of the scanned image. Choice: 150/200/ 300 /600 dpi
Color Mode:	Choose your desired color mode. Choice: Color 、Gray、B&W
Document Size:	Choose your scan size. Choice: A4, A5, Letter, B5
1/2-Sided:	Choose if you wish to scan one side or both the front and rear side of your document. Choice: 1-Sided 、2-Sided
Density:	Lighten or darken your original. Levels: 1~7 (default: 2)
File Format:	Choose your desired file format for the scanned image. Choice: M-PDF (Multi-Page PDF) 、PDF (One-Page PDF)、JPG、BMP、TIFF、M-TIFF (Multi-Page TIFF)

8. Tap the 「**Start**」 button  on the touch panel to start scanning and sending your document.



Notice:

- The product is preset with a default [From] e-mail address. If no [From] address, your e-mailed can not be forwarded successfully.
- The administrator of this product can preset a third-party's address as the sender's e-mail address to save user's time in typing the address. At the same time, add 「no reply」 in the original subject field to avoid recipients reply to the address. To preset the sender's e-mail address and the subject, press the 「Machine Status」 button on the control panel and press choose Tools>Default Settings>E-mail Default Settings in succession and modify the subject and sender's e-mail address.
- If your e-mail can not be forwarded, check with your Network Administrator if the [From] e-mail address has followed the rules set by your mail server.

Select one recipient from the Address Book

Address Book



Tap the button to select one recipient from the address book.

Tap the button and the following screen will be prompted. Choose one address from the left box and then tap the Right Arrow key ► to include the address to the list of your recipients.

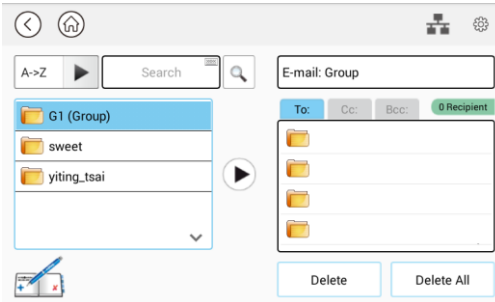

To edit the Address Book, tap  to prompt the following screen. You can add/modify/delete recipients' address in the screen.

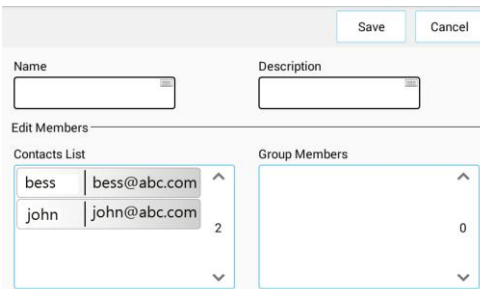

Tap **[Add Address]**  to prompt the following screen. Enter the recipients' name, and e-mail address.

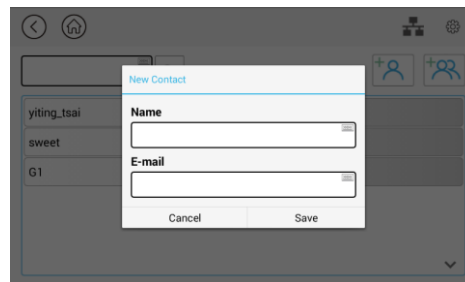

Or tap **[Add Group]**  to add a new group.

Common Settings:

Tap [**Common**] to set more settings for the scanned image that will be attached to the e-mail.

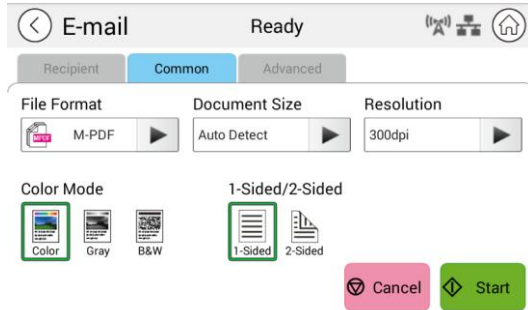

File Format	Choice: Multi-Page PDF , One-page PDF, JPG, BMP, TIFF, M-TIFF
Document Size	Choose your scan size. Choice: A4, A5, B5, Letter
Resolution	Choose the resolution of the scanned image. The higher the value, the more details can be reviewed yet more disk space will be required. Choice: 150/200/ 300 /600 dpi 150 dpi: Suits to be viewed on the screen. 200 dpi: Suits for most business document. 300 dpi/600 dpi: High quality image helps increase OCR (optical character recognition) accuracy.
Color Mode	Choose your color mode. Choice: Color , Gray, Black and White
1-Sided/ 2-Sided	Choose if you wish to scan one side or both the front and rear side of your document. Choice: 1-Sided , 2-Sided

* **Default settings to be shown in italic bold style**

Advanced Settings:

Tap [**Advanced**] to set more settings for the scanned image that will be attached to the e-mail.

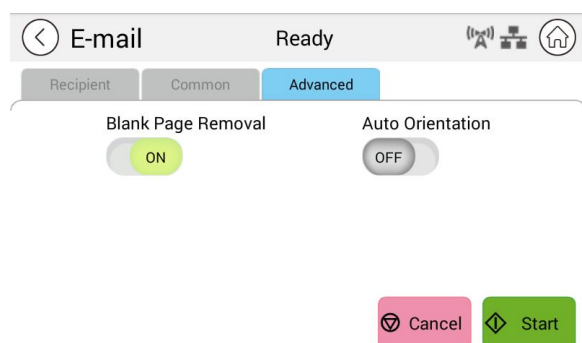

Blank Page Removal	Choose if you wish to automatically remove blank pages of your document. Choice: Off/ <i>On</i>
Auto Orientation	Choose if you wish to enable the function of automatically detecting the orientation of the original document. Choice: <i>Off</i> /On

* **Default settings to be shown in italic bold style**

Scan

The scan function allows you to first scan your documents and then send the scanned image to a specified destinations such as Scan to USB (an inserted USB flash drive) or Scan to FTP.

The Operational Steps:

1. Place your multi-page document **Face Up** and **Top First** in the auto document feeder or single-page **Face Down** on the document glass.
2. Slide the function buttons and then tap the 「**Scan**」 button on the touch screen, and the 「**Scan**」 screen will be displayed.

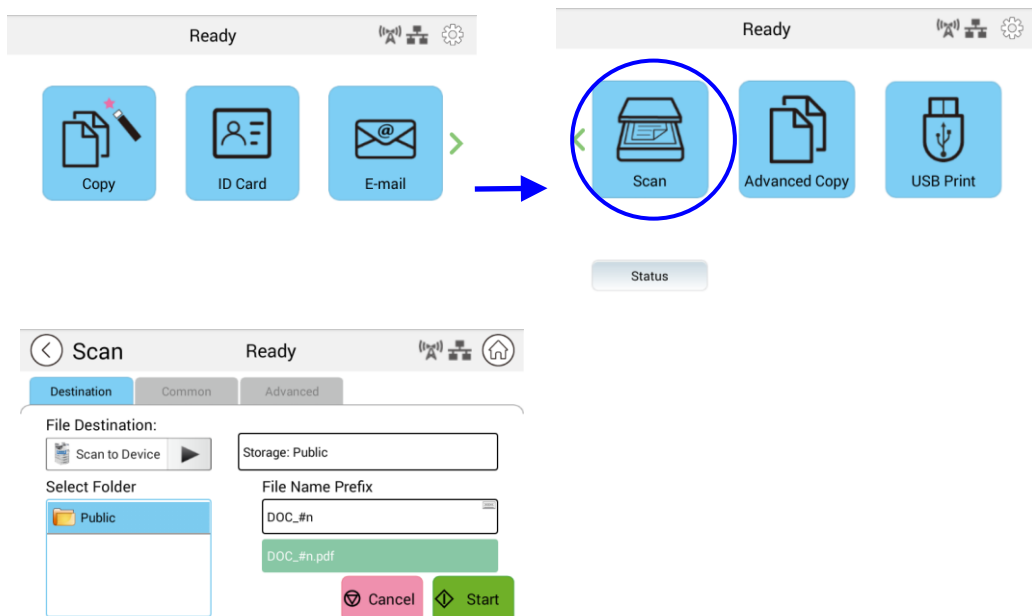

3. Tap 「Scan to Device」 to choose your scan-to destination.
 - **Scan to Device:** Send the scanned documents to the device's memory. (Download the image through the embedded web page.)
 - **Scan to USB:** Send the scanned documents to the inserted USB flash drive.
 - **Scan to FTP:** Send the scanned image to FTP server in the network.
 - **Scan to SMB:** Send the scanned image to the SMB server in the network.
3. Tap 「**Common**」 to confirm or change Scan options as desired such as Resolution, Output Color, Density, 1/2-Sided Scanning, File Format, Folder, or Document Size.

Resolution:	Choose the resolution of the scanned image. Choice: 150/200/ 300 /600 dpi
Color Mode:	Choose your desired color mode. Choice: Color 、Gray、B&W

Document Size:	Choose your scan size. Choice: A4, A5, Letter, B5
1/2-Sided:	Choose if you wish to scan one side or both the front and rear side of your document. Choice: 1-Sided 、2-Sided
Density:	Lighten or darken your original. Levels: 1~7 (default: 2)
File Format:	Choose your desired file format for the scanned image. Choice: M-PDF (Multi-Page PDF) 、PDF (One-Page PDF)、JPG、BMP、TIFF、M-TIFF (Multi-Page TIFF)

* The default settings is shown in italic bold style.

5. Tap the 「**Start**」 button  on the touch screen to start scanning and sending your document.

Destination Settings:

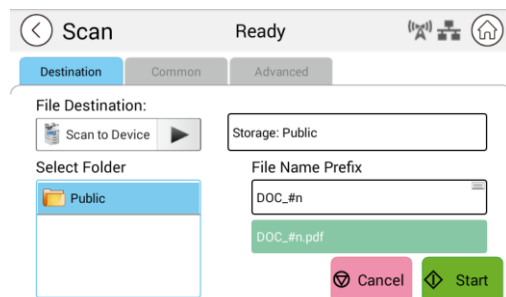

File Destination	<p>Choose the destination of your scanned document.</p> <p>Choice: Scan to Device/Scan to USB/Scan to FTP/Scan to SMB</p> <p>Scan to Device: The scanned image will be sent to the device's memory. (Download the image through the embedded web page.)</p> <p>Scan to USB: The scanned image will be sent to the USB flash drive inserted to the product.</p> <p>Note: The disk format for the USB flash drive supports only FAT16, and FAT32.</p> <p>Scan to FTP: Send the scanned image to FTP server in the network.</p> <p>Scan to SMB: Send the scanned image to the SMB server in the network.</p> <p>To edit (add/modify/delete) the FTP/SMB destination, please go to the product's embedded web site.</p>
Select Folder	Select a folder to store the job (scanned image).

File Name Prefix	<p>Tap the 「File Name Prefix」 field to enter your desired prefix.</p> <p>Naming Method : Prefix_#n. For example, 「Marketing_00003.pdf」 indicates Marketing(prefix) 00003 (serial number).</p>
------------------	---

Common Settings:

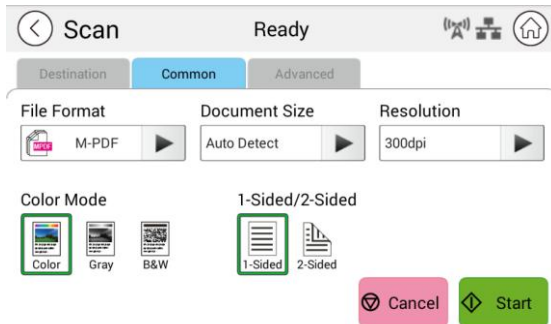

File Format	Choose your desired file format. Choice: <i>M-PDF (Multi-Page PDF)</i> , PDF (One-Page PDF), JPG, BMP, TIFF, M-TIFF.
Document Size	Choose your scan size. Choice: A4, A5, B5, Letter
Resolution	Choose the resolution of the scanned image. The higher the value, the more details can be reviewed yet more disk space will be required. Choice: 150/200/ 300 /600 dpi 150 dpi: Suits to be viewed on the screen. 200 dpi: Suits for most business document. 300 dpi/600 dpi: High quality image helps increase OCR (optical character recognition) accuracy.
Color Mode	Choose your color mode. Choice: Color , Gray, Black and White
1-Sided/ 2-Sided	Choose if you wish to scan one side or both the front and rear side of your document. Choice: 1-Sided , 2-Sided
* Default settings to be shown in italic bold style	

Advanced Settings:

Tap 「**Advanced**」 to set more settings.

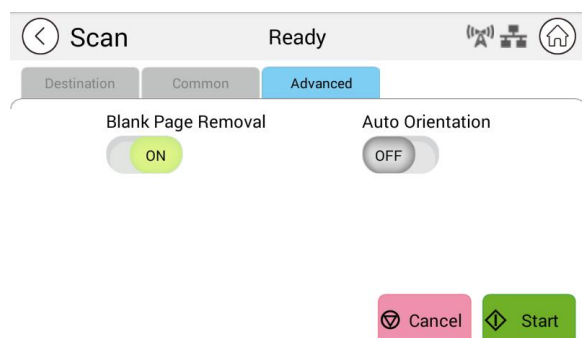

Blank Page Removal	Choose if you wish to automatically remove blank pages of your document. Choice: Off/ <i>On</i>
Auto Orientation	Choose if you wish to enable the function of automatically detecting the orientation of the original document. Choice: <i>Off</i> /On

* **Default settings to be shown in italic bold style**

Advanced Copy

The Operating Steps:

1. Place your multi-page document **Face Up, Top First** in the auto document feeder or place your single-page document **Face Down** on the document glass.
2. Slide the function buttons and then tap the 「**Advanced Copy**」 button, the following 「**Copy**」 screen will be displayed.

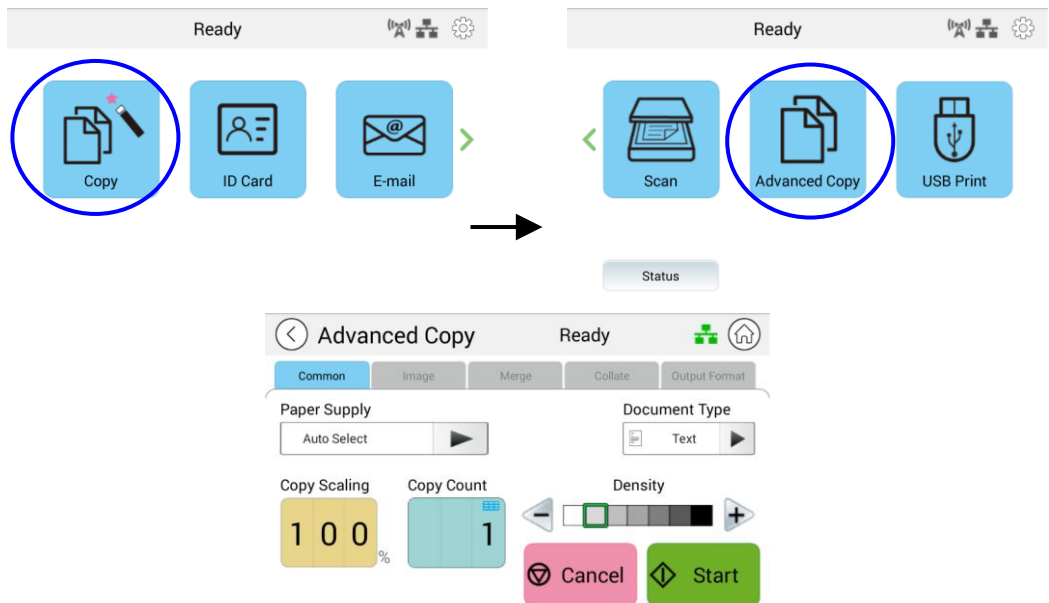

3. Confirm or change Copy options as desired such as Paper Supply, and Density.
4. Enter your copy count with the numeric keypad on the control panel. The number of copy count will appear on the upper right corner.
5. Tap the 「**Start**」 button  on the touch screen to start copying your document.

Copy Settings Description

Common Settings

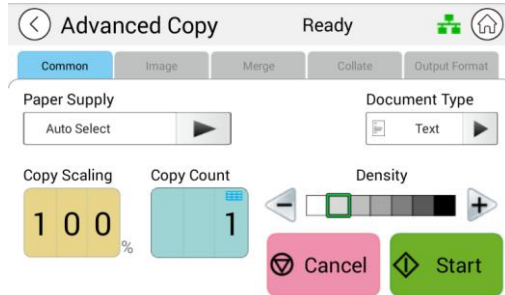

Paper Supply	Choice: Auto Select, Tray 1, Manual. Auto Select automatically helps a user find the input tray that best meets the desired paper size.
Copy Scaling	Choose if you wish to reduce or enlarge your original. Range: 25~400%; 100%
Copy Count	Enter your copy count.
Density	Choose your desired density level. Choice: 1~7 (Default: Text mode: 2, Mixed mode: 3)

* The default setting to be displayed in italic bold style

Image Settings

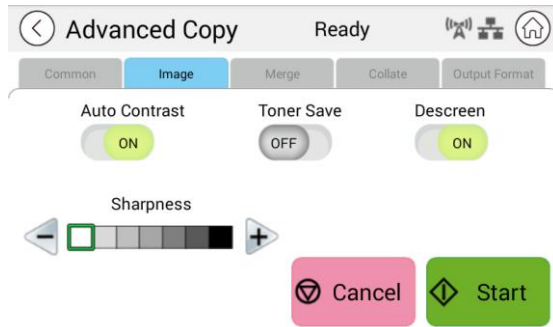

Auto Contrast	Choose if you wish to apply the product's default optimal contrast. Choice: <i>On</i> /Off
Toner Save	Choose if you wish to copy in toner save mode. Choice: On/ <i>Off</i>
Descreen	Remove the patterns on the printed material such as magazine. Choice: <i>On</i> /Off
Sharpness	Choose if you wish to increase or decrease the level of sharpness. Choice: (<i>1</i> ~7)

* The default setting to be displayed in italic bold style

Merge Settings

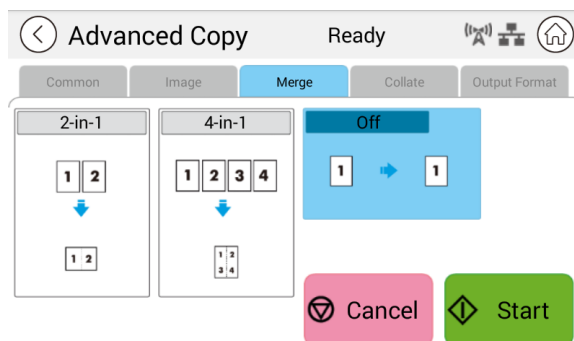

2-in-1	Combine 2 pages of your document into one single sheet of paper.
4-in-1	Combine 4 pages of your document into one single sheet of paper.
<i>Off</i>	Do not combine.

* The default setting to be displayed in italic bold style

Collated Settings

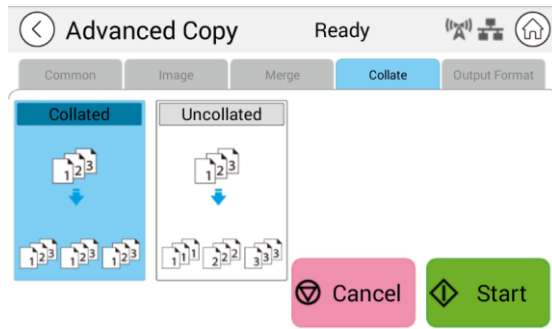

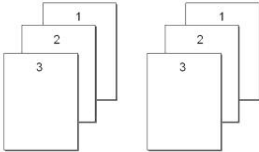
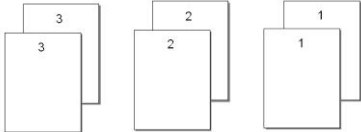



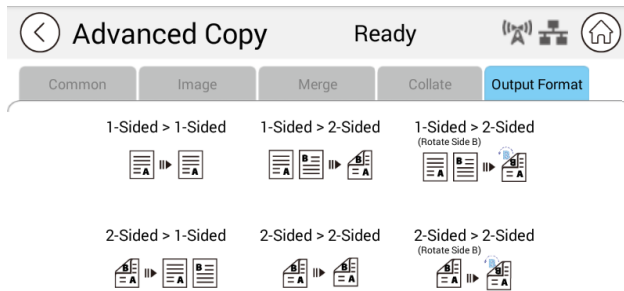

<p>Collated:</p>	<p>Choose your copies to be placed in "Sort" (e.g. pages 1,2,3/1,2,3/1,2,3) order.</p> 
<p><i>Uncollated:</i></p>	<p>Choose your copies to be placed in "Stack" (e.g. pages 1,1,1/2,2,2/3,3,3) order.</p> 

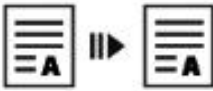
*** : Factory Default settings is displayed in italic bold style**

Output Format



<i>1-Sided>1-Sided:</i>	Copy single-sided originals onto one side of one sheet. 
1-Sided>2-Sided:	Copy single-sided original onto two sides of one sheet. 
1-Sided>2-Sided (Rotate Side 2):	Copy single-sided original onto two sides of one sheet with back page upside down. 
2-Sided>1 Sided:	Copy double-sided original onto one side of one sheet. 
2-Sided>2-Sided:	Copy double-sided original onto two sides of one sheet. 
2-Sided>2-Sided (Rotate Side 2):	Copy double-sided original onto two sides of one sheet with back page upside down. 

* : Factory Default settings is displayed in italic bold style

USB Print

The scan function allows you to print the JPG or PDF files stored in your removable flash drive. **Note:** The disk format for the USB flash drive supports only FAT16, and FAT32.

The Operational Steps:

1. Insert your removable USB flash drive to the USB port on the right side of the control panel.
2. Slide the function buttons and then tap the 「USB Print」 button on the touch screen. The 「USB Print」 screen will be displayed.

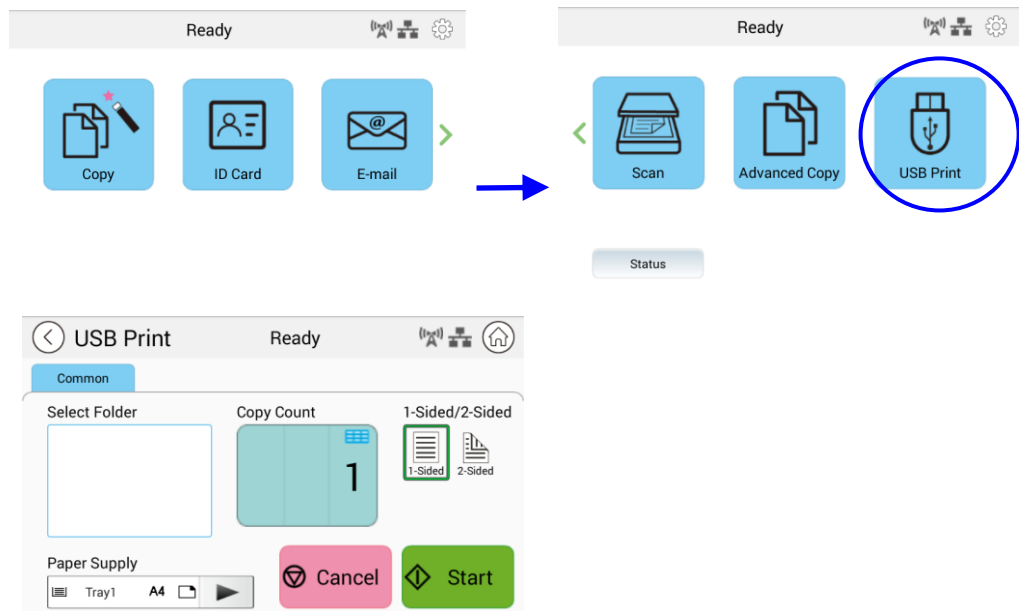

3. Swipe 「**Select Folder**」 to choose the folder which you store your file.
4. Confirm or change settings such as Paper Supply, Copy Count, 1/2-Sided.

1-Sided/2-Sided	Choose if you wish to scan one side or both the front and rear side of your document. Choice: 1-Sided 、2-Sided
Paper Supply	Choose your paper supply. Choice: Auto , Tray 1, Manual Tray Auto Select automatically helps a user find the input tray that best meets the scanning paper size.

* The default settings is shown in italic bold style.

5. Tap the 「**Start**」 button  on the touch screen to start printing your document.

5. Customizing the Product's Configurations

This chapter is specifically targeted to the persons who are responsible for the administration of the product. It is recommended that the administrator read this chapter before installing the machine.

The product's configurations can be customized via the touch screen and the control panel. In addition to using the touch screen, the product allows the administrator to remotely configure the machine by launching the product's embedded web page. How to customize the product's configurations via these two methods will be described in the following sections.



Note:

When installing the product for the first time, it is recommended that the Administrator retain the default system settings. The settings can be customized at a later date once you are familiar with the operation and functionality.

Customizing the Product's Configurations by the Touch Screen

Click [**More Settings**] and then choose [**Show Machine Status**]. This will prompt the following [**Machine Status**] page which contains 5 tabs.

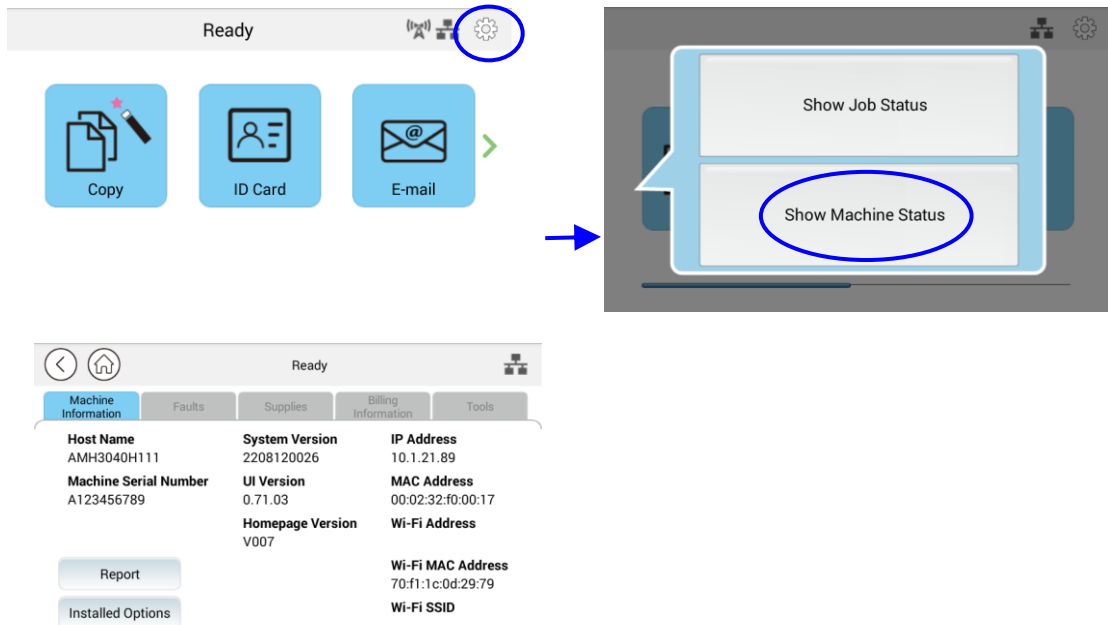

These 5 tabs displaying at the top are: Machine Information, Faults, Supplies, Billing Information, and Tools. For each respective option of the 5 tabs, refer to the descriptions of the next few pages.

Machine Information

General Information: Display the product's basic information.

Item	Description
Host Name	Displays the product's host name.
IP Address	Displays the product's IP address.
MAC Address	Displays the product's MAC address.
System Version	Displays the product's system version.
Engine Version	Displays the product's engine version.
UI Version	Displays the product's UI version.
Homepage Version	Displays the product's home page version.
Wi-Fi Mac Address	Displays the product's Wi-Fi Mac address.
Wi-Fi Address	Displays the product's Wi-Fi address.
Wi-Fi SSID	Displays the product's SSID name.

Report: Print out the product's various reports.

Item	Description
System Configuration Page	Prints the product's configuration page.
System Menu Map	Prints the product's menu map.
System Usage Page	Prints the product's usage report.
Address Book	Prints the product's address book.
Network Settings Report	Prints the product's network settings report.

Installed Options: Enable or disable the functions on the main screen.

Item	Description
Copy	Enable or disable the function.
ID Card Copy	Enable or disable the function.
E-Mail	Enable or disable the function.
Scan	Enable or disable the function.
Advanced Copy	Enable or disable the function.
USB Print	Enable or disable the function.

Faults: Display the current error items or warning message list.

Supplies

Supplies: Display the current states of supplies.

Item	Description
Toner usage remain	Displays the current remaining toner capacity in percentage.
Drum usage remain	Displays the current remaining drum unit capacity in percentage.

Billing Information

Billing Information: Used to display the usage status of the product's functions.

Item	Description
Flatbed Total Page Scanned to Copy	Displays total copy count using Flatbed.
ADF Simplex Page Scanned to Copy	Displays total copy count using ADF Simplex function.
ADF Duplex Page Scanned to Copy	Displays total copy count using ADF Duplex function.
ADF Total Page Scanned to Copy	Displays total copy count using ADF.
Counters	Displays the respective total cumulative usage number of the copy, printer engine, and scanner module.

Tools

Device Settings : Display the basic settings on the product.

Device Settings	
Item	Description
Language	Changes the language on the touch screen. Supported languages: English, 中繁, 中簡, Русский (Option varies according to your model.)
Date /Time	Sets up the current date and time on the product. The time format is 24-hour system.
Tray Contents (Tray 1)	Specify your copy size. Choice: A4, A5, A6, B5, B6, Letter, Legal, LG13, Oficio, User Define
Tray Contents (Manual Tray)	Specify your copy size. Choice: A4, A5, A6, B5, B6, Letter, Legal, LG13, Oficio, User Define
Selectable Paper Size	Choice: A4, A5, LTR, LGL
Media Type	Specify your media type. Choice: Thin, Thick, Plain, Laser, Bond (Manual Tray only)
Energy Save	Choose how long to enter the energy saving mode after your last action. Choice: Eco Mode , 5Min, 15Min, 30Min, 1Hr As Eco mode requires more time to return to the ready mode, to reduce the waiting time, you can change the default mode to other options.
Auto Power Off	Choose how long to enter the energy saving mode after your last action. Choice: Disable, 5Min, 15Min, 30Min, 1Hr, 2Hr, 4Hr
Schedule Restart	Enable or disable automatically restart the product on a preset schedule. Choice: On/Off, On (1~30 days)
Management	
Reset Default	All settings in Tools are back to the factory defaults. (keep address book and filing destination)
Reset All	All settings in Tools are back to the factory defaults.
Reset Count	Choose to reset count for roller or pad after replacement. Click [immediate] to reset count. Choice: ADF Pad, ADF Roller, Manual Tray Pad, Tray 1 pad

V-Mag Adjustment	Choose to adjust the vertical magnification rate of the PRINTER. Choice: -0.4%/-0.2%/*0%/+0.2%/+0.4 %
Clear Memory	Press to clear the printer's memory.
Clean Printer	Press to clean the printer's paper path.
System Timeout	When the touch screen has not been operated for a period of time, the system will automatically reset all settings in the touch screen back to the preset values and return to the main screen. System Timeout values available: From 5 seconds to 600 seconds. Each selectable interval range is 5 seconds. (30 sec.)
Display Brightness	Sets up the brightness on the touch screen.
Default Operating Mode	Set the default operating mode (function) on the touch screen. After timeout arrives, the specified default operating mode will be displayed. (Home/ Copy /Normal/E-mail/ID Copy/Scan/Advanced Copy)
Blank Page Detection Level	Choose your detection level to detect the blank page. Choice: Easy to be detected as document /Normal/Easy to be detected as blank page
Document Type	Choose if you wish to show or hide the option of document type. Choice: Hide /Show Document type includes Text and Mixed mode. Text: Select to sharpen your text. Mixed: Suitable for most typed originals.
Save Log	Choose and press [Start] to save system log file to your inserted USB flash drive to troubleshooting what reason cause your errors.
USB Control	USB Host: Enable or disable the connectivity of the USB flash drive port. USB Device: Enable or disable the connectivity of the USB device port at the back of the machine.
App plug-in	Enable or disable a third-party app to be installed and displayed in the touch panel.
FM Update	Click Start to update the firmware.

* **Default settings to be shown in italic bold style**

Default Settings: presets the default settings for each function.

Default Settings	
Item	Description
Copy Default Settings	Presets the default settings for Copy.
ID Card Copy Default Settings	Presets default settings for ID Card Copy.
Scan Default Settings	Presets the default settings for Scan.
E-mail Default Settings	Presets default settings for E-mail.
Address Book	Presets the address book.

Network Settings: presets the network default settings.

Network Settings	
Item	Description
Enable	<p>Enables or disables the product's Ethernet or Wi-Fi function. Choice: Off, Ethernet, Wi-Fi</p> <p>Wi-Fi: Available for Wi-Fi Station Mode. [Station mode: In Station mode, this product acts as a client that connects to a Wi-Fi Access Point (usually a Wi-Fi enabled router).</p>
Host Name	Sets up a host name for the product.
TCP / IP Settings	<p>Sets the connection methods and parameters of the product's network.</p> <p>DHCP : Enables or disables the DHCP. You don't need to specify the Static IP if you enable DHCP.</p> <p>IP Address/ Subnet Mask/ Gateway: if you disables DHCP, set up IP Address, Subnet Mask, and Gateway for your Static IP.</p> <p>DNS Server: Sets up a DNS server address for the product.</p>
SMTP	<p>Sets SMTP parameters of the product's network.</p> <p>Login Name: Input a login name for the product's SMTP server.</p>

	<p>Password: Enter a password for the product's SMTP server.</p> <p>Mail Server: Input an IP address or host name for the product's mail server.</p> <p>Port: Input a port number for the product's mail server.</p> <p>Authentication Method: Sets an authentication method (SMTP) for the product's mail server. Selecting None will not use an authentication method.</p>	
WI-FI Station Mode	Choose to use this product in Wi-Fi Station Mode.	
WI-FI AP Mode	Choose to use this product in WI-FI AP Mode.	
Network Security Setup	Enable or disable filter. Please go to the product's embedded web page to specify filter IP address.	
SNMP		
Enable SNMPv1/v2	On/Off	
Community name	Define your community name.	
Enable SNMPV3	On/Off	
User Name	Enter your user name. (1~32 characters)	
Authentication Protocol	MD5/SHA	
Invalid URL	Enter your invaoid URL address. (8~32 characters)	
Privacy Protocol	DES/AES-128	
Password	Enter your password. (8~32 characters)	
Context Name	Enter your context name.	
LDAP Server		
Enter your LDAP server information to load the e-mail address to the product to save your time to input these address.		
Network Port Settings		
HTTP Server	Turn on or off HTTP server.	*On/Off
SNMP Agent	Turn on or off SNMP agent.	*On/Off
Morpria Print	Turn on or off Morpria Print.	*On/Off
LPR	Turn on or off LPR.	*On/Off
Raw Print (9100)	Turn on or off raw print. Port: 9100	*On/Off
GDI Print (9101)	Turn on or off GDI print. Port: 9101	*On/Off

Customizing the Product's Configurations by the Webpage

1. Specify the network parameters by referring to the previous section, Specifying the Product's IP address and other Network Settings.
2. The product is designed with an embedded web page to allow the system administrator to remotely manage the product. Simply type the IP address of the product in the URL field of your browser and then press Enter. The product's embedded web page appears as shown below.

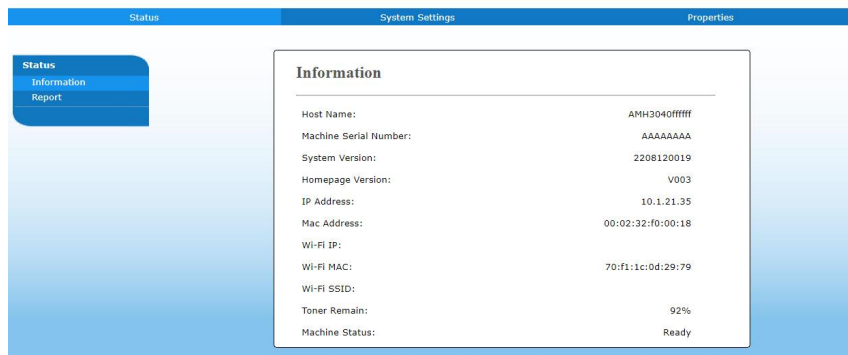

3. Click each item under these tabs to set up relevant values. For details on each setting, please refer to the subsequent section, Summary of the Web Pages.

Summary of the Webpage

The embedded web page contains the following five tabs, the Status tab, the Job tab, the Scan tab, the Print tab, and the Properties tab. Each of the tabs will be described in this section.

Items to be Customized

Status

Displays the status and basic information of the product.

Item	Description
Information	Display the following basic information of the product.
Host Name	Displays the host name.
Machine SN	Displays the machine's series number.
System Version	Displays the firmware version.
Homepage Version	Displays the version of the embedded web page.
IP Address	Displays the IP address.
Mac Address	Displays the Mac address.
Wi-Fi Mac Address	Displays the product's Wi-Fi Mac address.
Wi-Fi Address	Displays the product's Wi-Fi address.
Wi-Fi SSID	Displays the product's SSID name.
Toner Remain	Displays the toner remain of the toner cartridge.
Machine Status	Displays the machine status.

System Settings

*Factory Default

Item	Description	Option
Language	The language displayed on the LCD screen	* English, 中繁, 中簡, Русский (Option varies according to your model.)
NTP Server	Specify your NTP server.	
Time Zone	Specify local time zone.	
Date/Time	Sets up the current date and time on the product. The time format is 24-hour system.	
Copy Size	Choose your copy size.	Legal, Letter, A4, A5
Media Type	Choose your media type.	Thin, Thick, Plain, Laser, Bond (manual tray only)
Energy Save	Choose how long to enter the energy saving mode after your last action. *As ECO mode saving more energy, it requires more time to resume to the ready mode.	*ECO mode/5Min/15Min/30Min/1Hr
Auto Power Off	Choose how long to shut down the product automatically after your last action.	*Off/5Min/15Min/30Min/1Hr/2Hr/4Hr
Schedule Restart	Enable or disable [Schedule Restart]. If select on, enter number of day to restart the device automatically.	* On/Off
Management		
Rest Default	Reset all settings to factory default values but keep customer's settings such as address book, network destination.	
Reset Default All	Reset all settings to factory default values and do not keep customer's settings.	

Reset Count	Choose to reset count for roller or pad after replacement. Click [immediate] to reset count.	ADF Pad/ADF Roller/Tray 1 Pad/Manual Tray Pad
V-Mag Adjustmnet	Choose to adjust the vertical magnification rate of the printer.	-0.4%/-0.2%/*0% +0.2%/+0.4 %
Clear Memory	Press to clear the memory.	
Clean Printer	Press to clean the printer's paper path.	
Paper Count	Show the total page count.	
Timeout	When the machine has not been operated for a certain period of time, the system will automatically reset all settings back to the preset values. System Timeout Value : 0 ~ 300 seconds. Each selectable interval range is 15 seconds.	* On (60 secs)/Off
Default Mode	Set the default operating mode on the LCD screen.	* Copy , Home, ID Card Copy, E-mail, Scan, Advanced Copy, USB Print
Blank Page Detection Level	Choose your blank page detection strength.	Normal, Easy to be detected as blank pages, Easy to be detected as documents
Document Type	Choose if you want to show or hide the option of document type.	*Hide/Show
USB Host	Enable or disable the port of USB Host.	*Enable/Disable
USB Device	Enable or disable the port of USB Device.	*Enable/Disable
Account Password Length	Set no. of characters or digits of your password.	1~32

Properties

The **Properties** tab contains the following options: **FTP/SMB Setup**, **MFP's storage**, **Address Book**, **Network**, and **FW Update**.

FTP/SMB Setup: Used to display all destinations or create a new FTP or SMB destination to store the scanned images.

Item	Description
Add New	Click to add a new destination. Please enter your settings for the following items.
Filing Name	Type your file name.
Protocol	Choice: FTP, SMB
URL	Input the URL of a filing server.
Port	Type the port number of your filing server.
Login Name	Type the login name of your filing server if required.
Password	Type the password of your filing server if required.
Retype Password	Retype your password.
Copy	Check a file destination, and click this button to copy this destination settings including Protocol, URL, Port, Login Name, and Password.
Modify	Modify a current filing server.
Delete	Delete a current filing server.

MFP's storage: Used to download and delete files stored in the machine's memory. The scanned images will be named with a file name prefix of Doc and follow by a serial number.

Item	Description
Folder Operation	
Create New Folder	Used to create a new folder to store the images.
Manage Folder	Used to delete a folder.
Folders	
Public	Used to store the scanned images stored in the root directory. Action: Open, Delete, Download Timeout setting: Set the time you wish to delete the scanned images.

Address Book: Used to import /export an e-mail address book or a telephone directory.

Item	Description
Individual	Create, modify, or delete an individual e-mail address.
Group	Create, modify, or delete a e-mail group.
Import Address Book	Import an e-mail or a phone address book file in .csv file from your computer.
Export Address Book	Export an e-mail or a phone address book file in the product to .csv file. The address book file can be opened or modified via the Excel software.

Network

Displays the network information of the product.

*Factory Default

Item	Description	Option
Host Name		
Host Name	Display the host name for the product.	
TCP/IP Settings		
Obtain an IP address automatically	*Off/On	
IP Address:	Show the IP address of the product.	
Subnet Mask	Show the subnet mask number.	
Default Gateway	Show the gateway for your IP.	
DNS Server	Sets up the DNS server address for the product.	
WINS Server	Sets up the WINS server address for the product.	
802.1x EAP Setting		
802.1x EAP	*Off/On	
EAP Method	*PEAP/TLS/TTLS/MD5	
Phase 2 Authentication	*None/MSCHAPV2/GTC	
Root Certificate	*Off/On	
Identity	Enter the identify.	
Password	Enter the password.	
Wi-Fi Settings		
Search AP	Click [Search AP] and the currently connected wireless networks will be displayed. Select the wireless network you want to connect and then enter the security key if required.	
IP Settings	Obtain the IP address directly from the DHCP server or you may enter your static IP on the [IP Address], [Subnet Mask], [Gateway], [Preferred DNS Server] field respectively.	
Preferred DNS Server	Set the IP of your preferred DNS server.	
SMTP		
Mail Server	Enter the IP address of your SMTP server.	
Port	Enter the port number of the SMTP server. * 25	
Authentication Method	Enter the email authentication method. Choice: *On/Off	
Encrypt	Choose the encryption method of your emails to the SMTP server. Choice: *None, SSL, TLS/STARTTLS	
Login Name	Enter the login name for SMTP authentication.	
Password	Enter the password for SMTP authentication.	

Network Security Setup		
Security Configuration Filter	Specify if you wish to enable or disable the filter configuration.	*Disable/Enable
Filter Mode	Specify your filter mode to allow some IPs to access the device or deny some IPs from accessing the device.	Allow/Deny
IP Address Filter Configuration	<p>IP Address Filter Configuration- Four types of Start IP and End IP can be specified.</p> <p>Mac Address Filter Configuration- Up to 10 Mac address can be specified.</p>	IP Address Filter Configuration/ Mac Address Filter Configuration
Network Port Settings		
HTTP Server	Turn on or off HTTP server.	*On/Off
SNMP Agent	Turn on or off SNMP agent.	*On/Off
Morpria Print	Turn on or off Morpria Print.	*On/Off
LPR	Turn on or off LPR.	*On/Off
Raw Print (9100)	Turn on or off raw print. Port: 9100	*On/Off
GDI Print (9101)	Turn on or off GDI print. Port: 9101	*On/Off
SNMP		
Enable SNMPv1/v2	On/Off	
Community name	Define your community name.	
Enable SNMPV3	On/Off	
User Name	Enter your user name. (1~32 characters)	
Authentication Protocol	MD5/SHA	
Invalid URL	Enter your invaoid URL address. (8~32 characters)	
Privacy Protocol	DES/AES-128	
Password	Enter your password. (8~32 characters)	
Context Name	Enter your context name.	
LDAP Server		
Enter your LDAP server information to load the e-mail address to the product to save your time to input these address.		
Certificate Upload		
Allow you to upload certificate or enter password to access a specific server.		

Security

The availability of this function varies according to your model.

Item	Description
User Authentication	Enable or disable user authentication.
Account Management	Allow the administrator to create new accounts to access the specified functions. Options: New/Modify/Delete

FW Update

Update the firmware of the product. Before updating the product's firmware, you need to first download the latest firmware from our web site at www.avision.com onto your computer. On the webpage, choose [**Browse**] to find the firmware file on your computer and then choose [**Update**] to begin updating the firmware to the product.

App Plug-In

Select [**Enable**] to install a third-party application on the product. The third-party plug-in app allows users to complete the scan tasks according to its own workflow. For more detailed information, please contact the manufacturer first.

A+ Manager Settings

Check [**Enable**] and then enter the IP address of a specified server to send the system log file to for quick troubleshooting.

6. Configuring the Printer Driver

Displaying the Printer Driver Properties Dialog Box

To display the Printer Driver Properties dialog box,

1. Click **Start** on the system tray and choose **Printers and Faxes**.
2. Right-click the product's printer name and choose **Printing Preferences**.



3. The Printing Preferences dialog box.

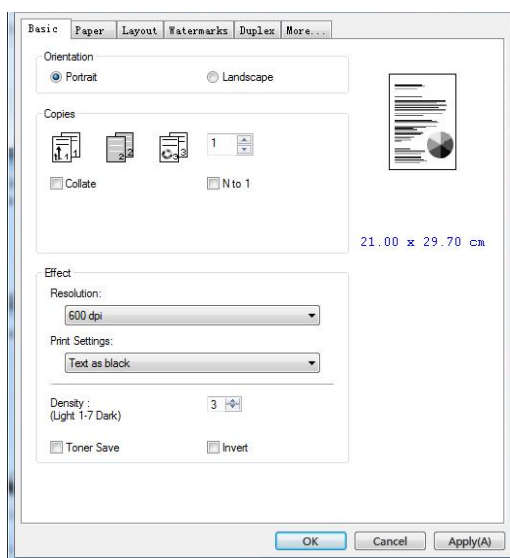

Configuring Printer Driver Settings

The Printing Preferences dialog box consists of the Basic tab, the Paper tab, the Layout tab, the Watermark tab, the Duplex tab, and the More tab. The contents of each tab will be explained in the following sections.

The Basic Tab

The Basic tab contains settings for Orientation, Copies, Effect, Density, Toner Save, and Invert.

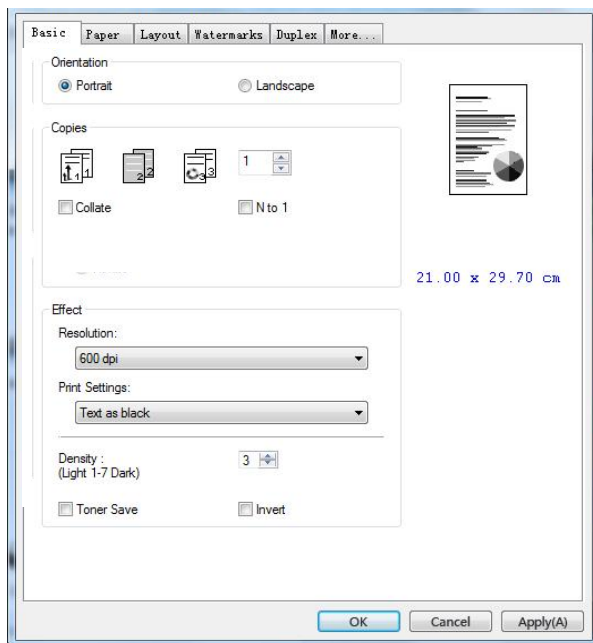

Orientation

Choose your orientation. **Choice: *Portrait, Landscape**

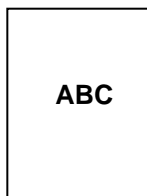

Portrait

*Factory Default

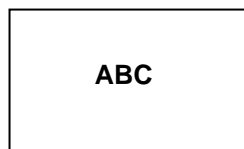

Landscape

Copies

Choose the number of copies to be printed. You can enter up to 999.

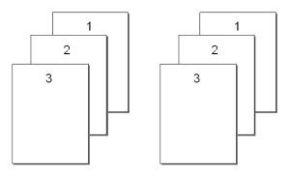
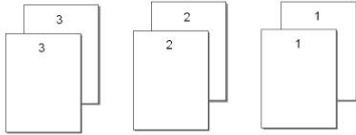
<p>Collate:</p>	<p>Click to print your document in the page order such as 1/2/3, 1/2/3, 1/2/3.</p> 
<p>N to 1:</p>	<p>Click to reverse the printing order of your document. As a result, the last page of your document will be printed first and vice versa.</p> 

Effect

<p>Resolution:</p>	<p>Choice: *600 dpi, 1200 dpi HQ *Option varies due to your printer model. 600 dpi: for normal document. 1200 dpi: Choose 1200 dpi if you wish to enhance the print quality.</p>									
<p>Print Settings:</p>	<table border="1"> <tr> <td data-bbox="670 1272 922 1305">Normal:</td> <td data-bbox="922 1272 1315 1305">Normal mode.</td> </tr> <tr> <td data-bbox="670 1305 922 1406">**Picture Mode:</td> <td data-bbox="922 1305 1315 1406">Suitable for your document containing pictures.</td> </tr> <tr> <td data-bbox="670 1406 922 1473">Text as Black:</td> <td data-bbox="922 1406 1315 1473">Print color text in pure black.</td> </tr> <tr> <td data-bbox="670 1473 922 1541">**Enhance Text:</td> <td data-bbox="922 1473 1315 1541">Make the text bold.</td> </tr> </table> <p>** These features are only available for GDI printer language.</p>		Normal:	Normal mode.	**Picture Mode:	Suitable for your document containing pictures.	Text as Black:	Print color text in pure black.	**Enhance Text:	Make the text bold.
Normal:	Normal mode.									
**Picture Mode:	Suitable for your document containing pictures.									
Text as Black:	Print color text in pure black.									
**Enhance Text:	Make the text bold.									
<p>Density:</p>	<p>Click to lighten or darken your document. Density level (1~7). Default: 3</p>									
<p>Toner Save:</p>	<p>Allows you to print your document using the toner saving mode.</p>									
<p>Invert:</p>	<p>Invert makes each image pixel inverted to its complementary color. For example: the original black text on white background becomes white text on black background.</p>									

*Factory Default

The Paper Tab

The Paper tab contains settings for Original Size, Tray, and Media Type.

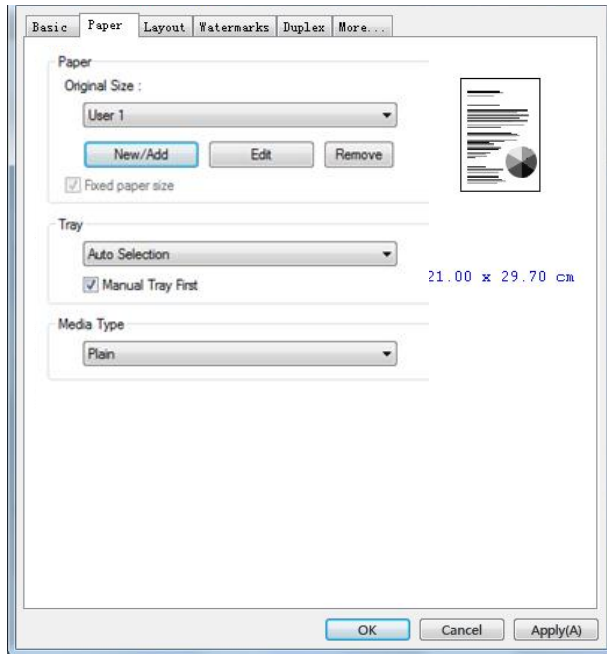

Paper

Original Size:	<p>Choose the size of paper loaded in the designated tray.</p> <p>Choice: *A4, A5, A6, B5 (JIS), B6 (JIS), Legal, Legal 13, Oficio, Letter, User Define</p> <p>Click [Add/New] to create up to 20 sets of custom size.</p>
Tray:	<p>Choose the tray from which your paper should be fed.</p> <p>Choice: Auto Selection, Manual Tray, Tray 1</p> <p>*Manual Tray First: Automatically select the paper tray which is available (priority: 1: Manual Tray; 2: Tray 1).</p> <p>Auto Selection: Automatically select the paper tray which is available (priority: 1: Tray 1; 2: Manual Tray).</p>
Media Type:	<p>Choose the type of media to be used for printing.</p> <p>Choice: *Plain, Thin, Thick, Laser, **Bond</p> <p>**: Only available in the manual tray for one-side printing</p>

*Factory Default

The Layout Tab

The Layout tab contains settings for N-up, and Output Paper Size.

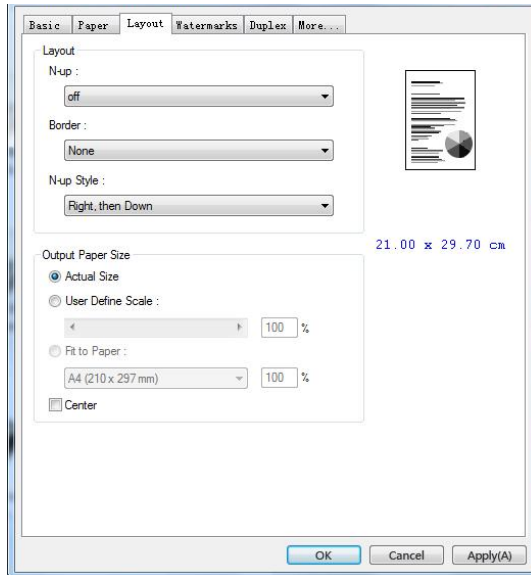

Layout

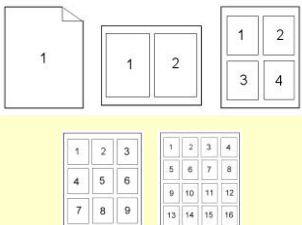
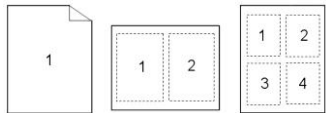
<p>N-up:</p>	<p>Choose number of pages to be printed on a single sheet of paper.</p> <p>Choice: *Off, 2up(2-in-1), 4-up(4-in-1), 9-up(9-in-1), 16-up(16-in-1)</p> 
<p>Border:</p>	<p>Choose if you wish to add border around each page when printing more than one page on a single sheet of paper.</p> <p>Choice: *None, Border Line, Dashed Line</p> 

* Factory Default Setting

N-up Style:	Choose the style you want when printing multi-page document on a single sheet.	
	Choice: *Right, then Down/Down, then Right/Left, then Down/Down, then Left	
	<p>Right, then Down</p>	<p>Down, then Left</p>
	<p>Down, then Right</p>	<p>Left, then Down</p>

* Factory Default Setting

Output Paper Size

*Actual Size	Print the actual size of your document.
User Define Scale	You can reduce or enlarge your printed image using the Slider Bar. Scaling rate: 25%~400% (*100%)
Fit to Paper	Output the full page of the selected original including the four margins.
Center	Print your image in the center of the output paper.

* Factory Default Setting

The Watermark Tab

The Watermark tab allows you to add some text or image (such as CONFIDENTIAL, IMPORTANT, DRAFT, etc) for your document.

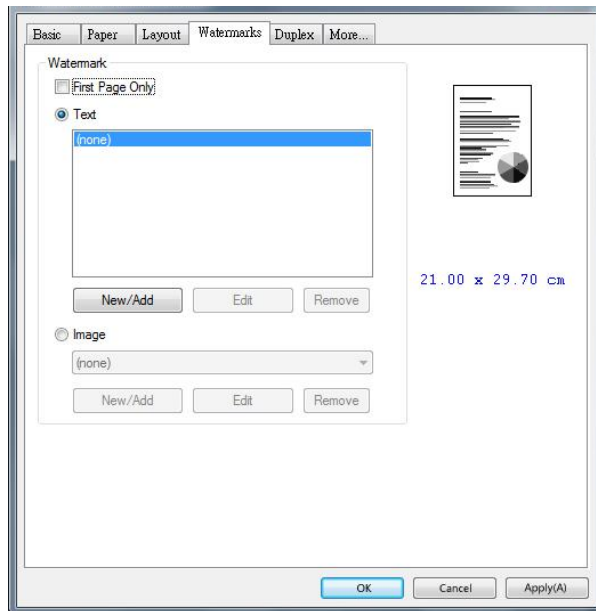

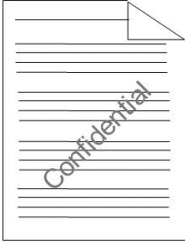
First Page only	Check to print watermark only on the first page. Clear the check box will print watermark on all pages.
Text	Choose and click New/Add to add new watermark text. Click the Edit button to change or the Remove button to delete. 
Image	Choose and click New/Add to add watermark image. Click the Edit button to change or the Remove button to delete. You can choose your image in file format such as BMP, TIFF, or JPG.

Adding a new watermark text

To add a new watermark text,

1. Choose **Text** and then click the **Add/New** button. The following Watermark dialog box appears.

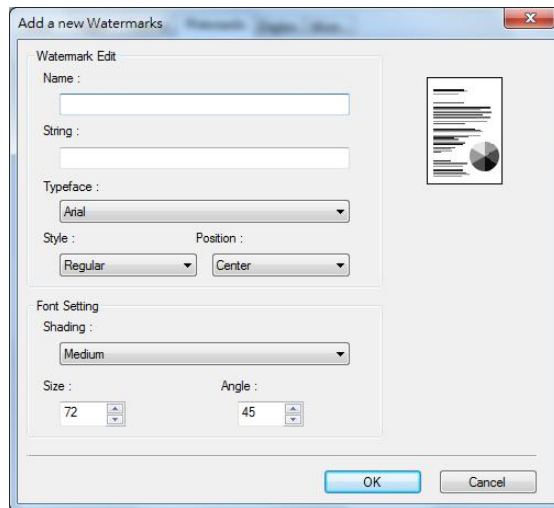

Name	Name your watermark text. This name will be shown in the Watermark text list.
String	Enter your watermark text, such as confidential, important, and so on.
Typeface	Choose your font type for your watermark text.
Style	Choose the style of your watermark text. Choice: *Regular, Bold, Italic, Bold Italic.
Position	Choose the position of your watermark text. Choice: *Center, Tile.
Shading	Specify a relative density for the watermark text. Choice: Lightest, Light, *Medium, Dark, Darkest.
Size	Specify the size of your watermark text from 1 to 288 . (*72)
Angle	Specify the angle of the watermark text from 0° to 360° (*45°)

* Factory Default Setting

2. Click the **OK** button to save the settings. If the new watermark text is created successfully, the watermark name will be shown in the Text list.

Editing a current watermark text

To edit a current watermark text,

1. Choose the watermark name that you wish to edit from the Text list.
2. Click the **Edit** button. The Watermark Edit dialog box appears.
3. Change your settings for the selected watermark text and choose **OK** to complete.

Removing a current watermark text

To remove a current watermark text,

1. Choose the watermark name that you wish to remove from the Text list.
2. Click the **Remove** button. The watermark text will be removed.

Adding a new watermark image

To add a new watermark image,

1. Choose **Image** and then click the **Add/New** button. The following Watermark dialog box appears.

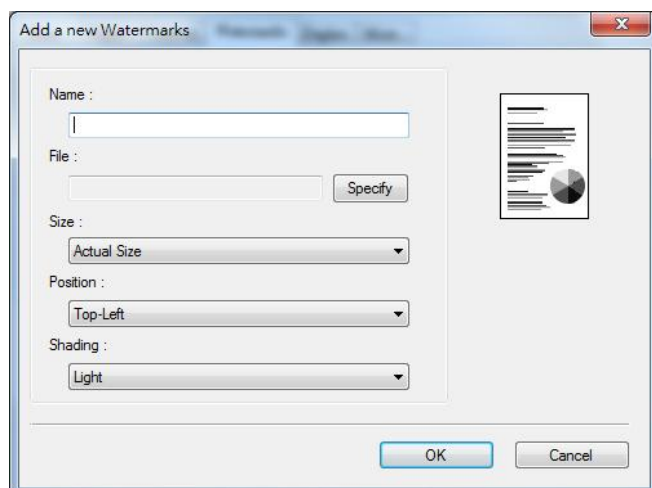

Name	Name your watermark image. This name will be shown in the Watermark image list.
File	Click the Browse button to locate your watermark image.
Size	Specify the size of your watermark image. Choice: *Actual Size, Shrink to Page, Tile.
Position	Choose the position of your watermark image. Choice: *Top-Left, Top-Center, Top-Right, Center, Center-Left, Center-Right, Bottom-Center, Bottom-Right, Bottom-Left.
Shading	Specify a relative density for the watermark text. Choice: Lightest, *Light, Medium, Dark, Darkest.

* Factory Default Setting

2. Click the **OK** button to save the settings. If the new watermark image is created successfully, the watermark name will be shown in the Image list.

Editing a current watermark image

To edit a current watermark image,

1. Choose the watermark name that you wish to edit from the Image list.
2. Click the **Edit** button. The Watermark Edit dialog box appears.
3. Change your settings for the selected watermark image and choose **OK** to complete.

Removing a current watermark image

To remove a current watermark image,



1. Choose the watermark name that you wish to remove from the Image list.
2. Click the **Remove** button. The watermark image will be removed.

The Duplex Tab

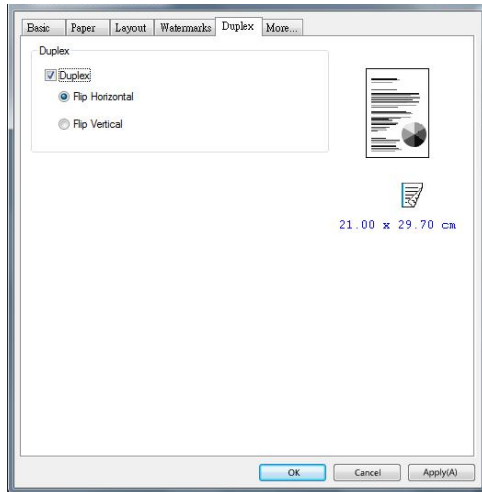
The Duplex tab allows you to print your document on two sides of the paper.
Choice: Flip Horizontal, Flip Vertical.

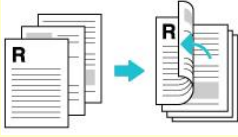
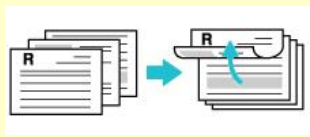
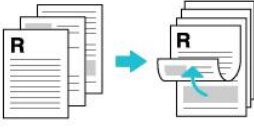

When using **Two-Sided** printing, you can select whether to bind copies on the long-edge or short-edge.

<p>Long Edge (Binding)</p>	<p>Long-Edge binding (Portrait) will print the pages so that you flip them like you would do on a book.</p> <div style="display: flex; justify-content: space-around;"> <div style="text-align: center;">  <p>Long-Edge binding (Portrait)</p> </div> <div style="text-align: center;">  <p>Long-Edge binding (Landscape)</p> </div> </div>
<p>Short Edge (Binding)</p>	<p>Short-Edge binding (Portrait) prints them so that your flip them like you would do on a calendar.</p> <div style="display: flex; justify-content: space-around;"> <div style="text-align: center;">  <p>Short-Edge binding (Portrait)</p> </div> <div style="text-align: center;">  <p>Short-Edge binding (Landscape)</p> </div> </div>

* Factory Default Setting

Note: The duplex feature supports only page sizes of Legal, Legal 13, Oficio, A4, B5 (JIS), User Define (>B5), and letter with paper weight between 60g/m² and 105g/m².

The More Tab

On the **More** tab, a **Wait Timeout** option is provided to set the amount of time the PRINTER waits for data to come from computer during a job. If the data stream pauses for longer than the specified number of seconds, the job is cancelled.

Permitted timeout values: 60~1800 seconds, default timeout values: 300 seconds

Clean Mode: If unwanted image appears in the blank space, you can check "Clean Mode" to improve the printing quality.

Uniform Mode: If uneven shading appears in the image area, you can check "Uniform Mode" to improve the printing quality.

Defaults: Press to change all setting values back to factory default.

Clean Page: After pressing the button, the machine will immediately print a cleaning chart to clean the excessive toner in the printer.

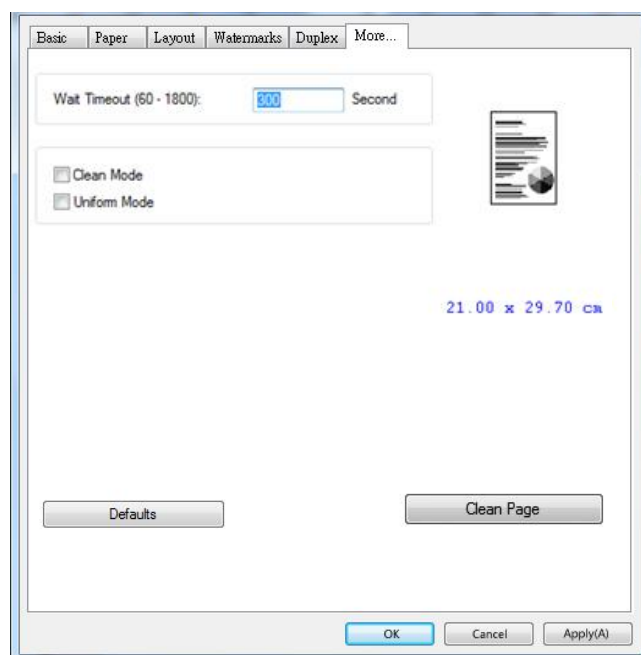

7. Printing Documents from a Mobile Device

For the model comes with a Wi-Fi module, the product can be converted into a wireless device and your mobile device is able to print emails and documents by simply tapping Print from the menu. (The availability of Wi-Fi function varied according to your model name.)

Making Preparation

To connect the product to a wireless LAN, prepare the followings:

- **An environment in which a wireless LAN is available**

When connecting the scanner to a wireless LAN, you may need information for a wireless access point such as an SSID (network name) and a security key (password). For details, contact your Network Administrator or refer to the manual for the wireless access point.



Attention!

Do not place obstacles that block radio waves (e.g. walls or metal plates) or devices that cause radio wave interference (e.g. cordless phones) within 100 mm of the product, or near your wireless access point.

- **Mopria Print Service**

The Mopria Print Service (app) can be downloaded from the Google Play Store to enable print functionality on any Android phone or tablet (Android version 4.4 or later). Once installed, simply connect your device to the same network as the printer and your mobile print can be completed.

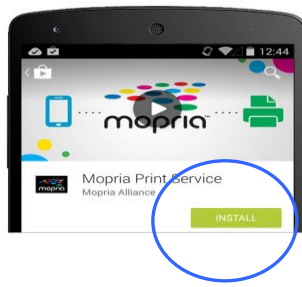

Connecting to a Wireless Network

Refer to Chapter 5 to choose Tools>Network>Wi-Fi Settings on the touch panel or the Properties>Network>Wi-Fi settings on the product's web page to connect the product to a wireless network.

Printing Your File from a Android Mobile Device

Make sure that the Mopria Print Service (Print App) has been installed on your Android mobile device. The **Mopria Print App** can be purchased for free from an application store such as Google Play.

1. Select the same wireless network as your PRINTER.

On your mobile device, tap **Settings>Wi-Fi** and choose the same network name (SSID) of your PRINTER.

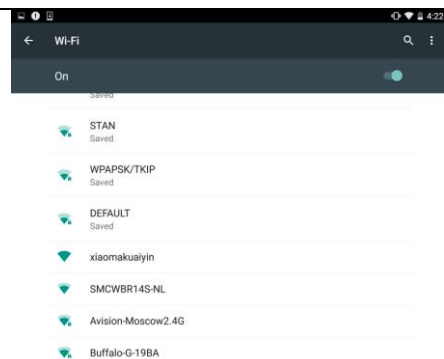

2. **Turn Mopria Print Service on.** The device will search available PRINTERS.

On your mobile device, tap **Settings>Printing>Mopria Print Service** to turn Mopria Print Service on. The Device will search for all available PRINTERS.

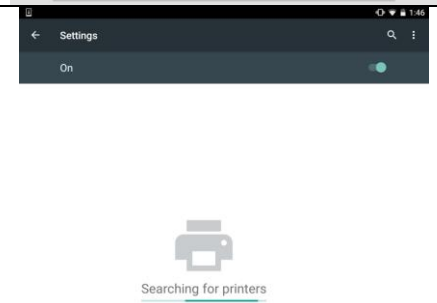
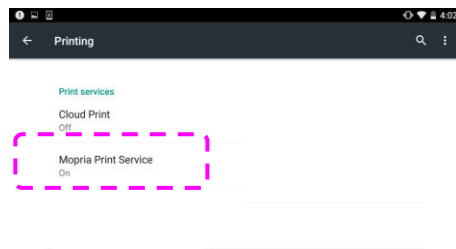
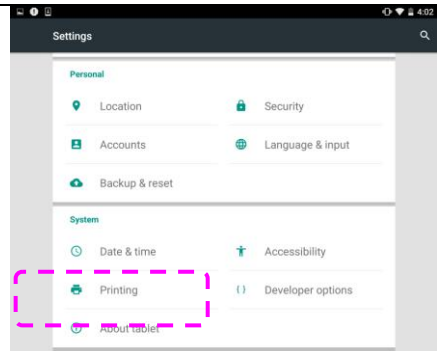

3. Select your PRINTER.

Select [**XXX at XXX**] from the PRINTER list.
(XXX=Modellnummer)

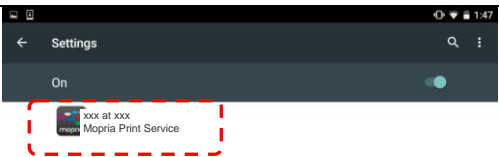

4. Open the file which you want to print.

Open the file you want to print.

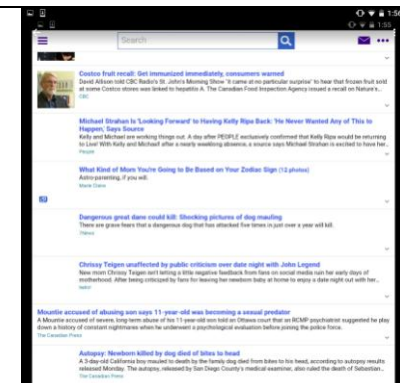

5. Choose [**Print**] from the menu and select your PRINTER.

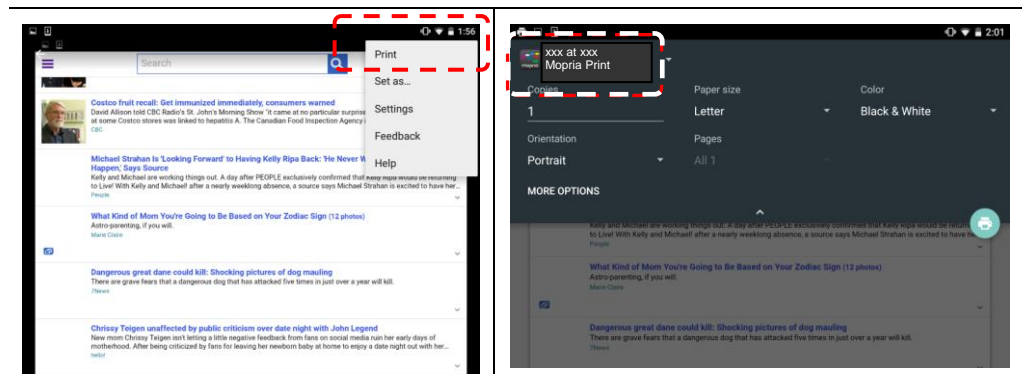

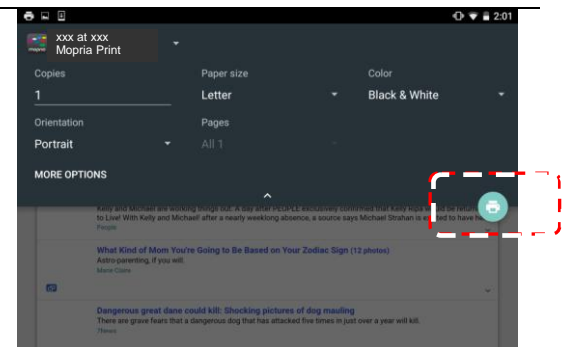

6. Choose print settings and print.

- If you do not need to change print options, tap **Print** to send the print job.
- If you need to change print options, continue to the next section.



Printing Your File from a iOS Mobile Device

1. Turn on your mobile devices such as iPhone or iPad.
2. Tap 「**Settings**」 and then open Wi-Fi. Select the network same with your PRINTER.
3. Open the picture or the document that you want to print. Tape the Share icon () and then the print icon ().

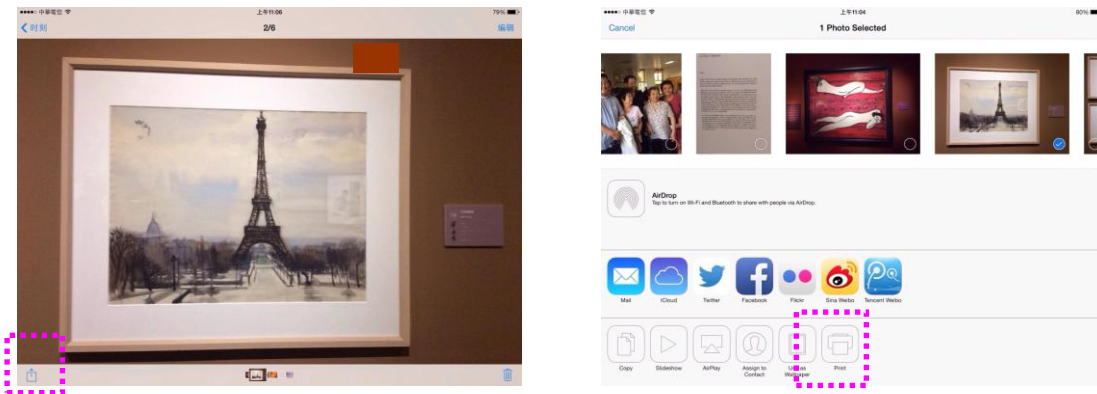

4. Tap [Select PRINTER] and choose your desired PRINTER. (xxx=model name)

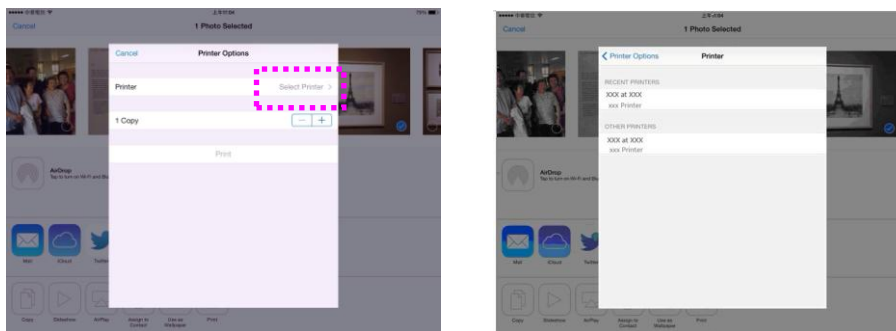

5. Tap [Print] to start printing.

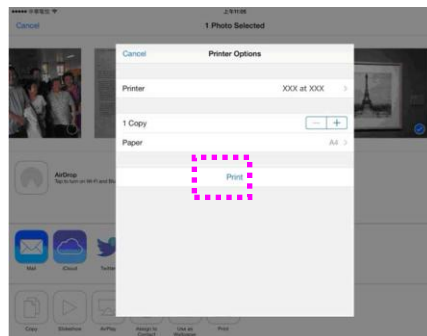

8. Scanning From Your Computer

After installing the scanner driver and connecting the USB cable to your computer, the product can be used as a fine scanner. You can use various scanning features to modify your scanned image.

Scanning via Image Editing Applications

1. Start your image editing application.
2. Pull down the **File** menu and choose **Select Source**.

If the **Select Source** command is not available on the **File** menu, see your application's user's guide to determine how the TWAIN link is used. A dialog box with a list of scanning sources appears.

3. Select the model name of your product.

You need to select the source only once, unless you want to choose another scanner.

4. Place the document **FACE DOWN** on the flatbed glass.
5. Pull down the File menu and choose **Acquire**.

A dialog box containing scanning features appears.

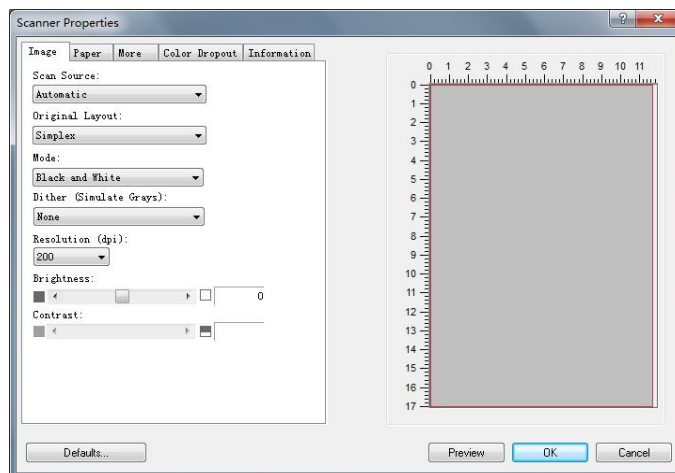

6. Select the scanning method you want to use on the **Scan Source** drop-down menu.

- 7.** Select the mode you want to use for your scans on the **Image Mode** drop-down menu.
- 8.** Select a scanning resolution on the **Resolution** drop-down menu.
- 9.** Select the setting for the scanning features (e.g. Brightness, Contrast, Original Layout, etc.) that you want to use.
- 10.** Click on **Preview** or **Scan** to preview or scan your documents.

Using The Image Tab

Selecting A Proper Image Mode

- ➔ **Black & White:** Choose B&W if your original contains only B&W text, pencil or ink sketch.
- ➔ **8-bit Gray:** 8-bit Gray images contain actual shades of gray.
- ➔ **24-bit Color:** Choose 24-bit Color if you wish to scan a color image.

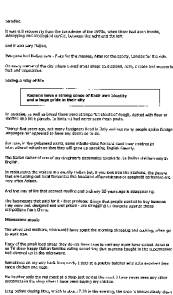

B&W



Gray



Color

- ➔ **Dither (Simulate Grays):**
This is the process of converting a grayscale or color image to a bi-tonal image. There are several different methods of performing this conversion. **Options: None, Halftone 1~5, Diffusion.** Default setting is none.

- ➔ **Halftone:**
In addition to the black and white display, halftone can present a somehow gray shade of image by using different size of dots. Halftone image looks like the picture you have seen in the newspaper. **Options include Halftone 1, Halftone 2, Halftone 3, Halftone 4, Halftone 5.**

- ➔ **Diffusion:**
Diffusion is a type of halftone. Diffusion gives good image texture and makes text in images more readable than halftone.



Error Diffusion Image



Halftone Image

Determining Proper Resolution

A proper resolution reproduces a clear image with good details. The resolution is measured by dots per inch (dpi). The resolution is measured in pixels per inch (ppi) (sometimes referred to as dots per inch or dpi). Higher resolutions result in more detail in the scan, slower scanning and in general, greater file sizes. For example, an A4 size color image scanned at 300 dpi with color mode consumes approximately 25 MB of disk space. When OCR (Optical Character Recognition) is to be performed on a scan, 300dpi should be used for most languages except Asian languages. For Asian languages, 400 dpi is recommended.

Choose a resolution value from the drop down list. The default value is 200 dpi. Available resolutions are 75, 100, 150, 200, 300, 400, 500, 600 and 1200 (1200: available for fixed paper size).



Resolution: 75 dpi



Resolution: 150 dpi

Adjusting Brightness And Contrast

→ **Brightness**

Adjusts the lightness or darkness of an image. The higher the value, the brighter the image. Drag the slider to the right or left to increase or decrease the brightness. The range is from -100 to +100. The default value is 0.

→ **Contrast**

Adjusts the range between the darkest and the lightest shades in the image. The higher the contrast, the bigger the different grayscale. Drag the slider to the right or left to increase or decrease the contrast. The range is from -100 to +100. The default value is 0.

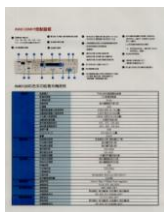

Brightness: -50

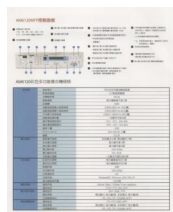

**Brightness: 0
(Normal)**

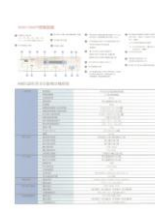

Brightness: +50



Contrast: -50



**Contrast: 0
(Normal)**

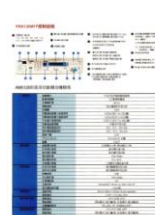

Contrast: +50

Choosing Scan Source

Choice:

Flatbed: Select this setting if you need to scan a single page from the flatbed.

***Auto, ADF**—Use this setting if you are using the automatic document feeder (ADF) to scan documents at a time.

Preview Window

Click the Preview button to get a scanned image in a low resolution. You can use this window to select your scan area.

Using The Paper Tab

Selecting Your Scan Size

- **Custom:** Choose **Custom** from the **Cropping** drop-down list on the **Paper** tab. This feature allows you to define the area or zone to be scanned. If you select this option, you can enter the x and y offset values, width and length to redefine your scanned area. The Display window will show the size as you change the values.

Choose your scan size from the **Scan Size** drop-down list.

None
US Letter- 8.5"x 11"
US Legal – 8.5" x 14"
ISO A4 – 21 x 29.7 cm
ISO A5 – 14.8 x 21 cm
ISO A6 – 10.5 x 14.8cm
ISO A7 – 7.4 x 10/5 cm
ISO B5 – 17.6 x 25 cm
ISO B6 – 12.5 x 17.6 cm
ISO B7 – 8.8 x 12.5 cm
JIS B5 – 18.2 x 25.7 cm
JIS B6 – 12.8 x 18.2 cm
JIS B7 – 9.1 x 12.8 cm
Scanner Maximum
Long Page (<118")

The following options are only available when **Custom** is selected.

- **X-Offset** — the distance from the left end of the scanner to the left edge of the scanning area.
- **Y-Offset** — the position from the top end of the document to the top end of the scanning area.
- **Width** — the width of the scanning area.
- **Length** — the length of the scanning area.
- **Center** — automatically calculates the x-offset for center-fed feeding based upon document size selected.

Unit: Define your measurement system. **Inches, Millimeters,** and **Pixels** are available.

Using The More Tab

Enabling Multi-Feed detection

The multi-feed detection feature allows you to detect overlapped documents that go through the scanner. Multi-Feed usually occurs due to stapled documents, adhesives on documents, or electro-statically charged documents.

Additional Length Detection: Additional Length Detection allows you to define the length of document being multi-fed. This value indicates the additional length exceeding your scan area. A value of 0 indicates no additional length detection. For the specified measuring unit, please refer to the Unit drop-down list box on the Paper tab. Once multi-feed is detected, the scanning operation will not be stopped. Instead, a multi-feed detection message will be displayed.

Color Dropout

This dialog allows you to remove one of the R (Red), G (Green), or B (Blue) color channel. This function is particularly useful when you need to convert text using OCR software. Note that this function supports only black & white and gray image. Therefore, be sure to choose any black & white or gray image type while applying this function.

Using The Information Tab

The **Information** Tab allows you to view all the information about the scanner including serial number, pad count, roller count, and firmware version. These are helpful information when you report a problem to the service personnel.

9. Maintaining the Product

Cleaning the Glass

The product is designed to be almost maintenance-free. However, it still needs to be cleaned occasionally to ensure optimum image quality and performance.

To clean the glass,

1. Open the document cover as shown below.
2. Dip a soft clean cloth with isopropyl alcohol (95%).
3. Gently wipe the flatbed glass and the white sheet beneath the document cover to remove the dust or any toner particles.
4. Close the document cover. Your machine is now ready to use.

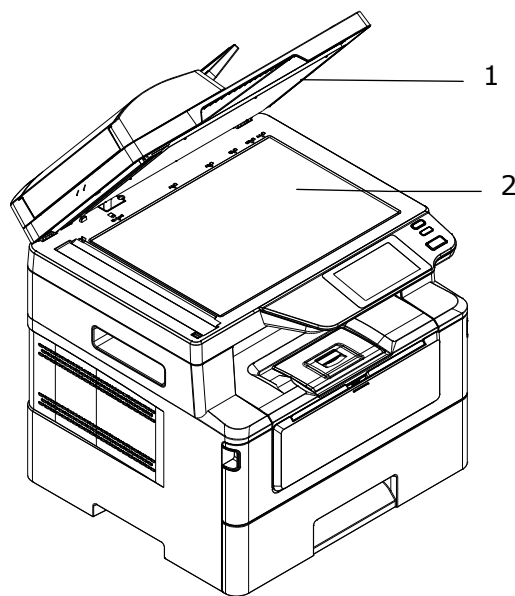

1. Document Cover
2. Flatbed Glass

Cleaning the Pad in the Cassette

If the Pad in the Cassette is smeared with paper powder or dirt or every 30K copies, paper may not feed smoothly or noise occurs during paper feeding. Follow the procedure below to clean the Pad in the Cassette.

You need to prepare: cotton swab

1. Remove all paper in the cassette.
2. Moisten a cotton swab with isopropyl alcohol (95%).
3. Clean the rubber part of the pad.

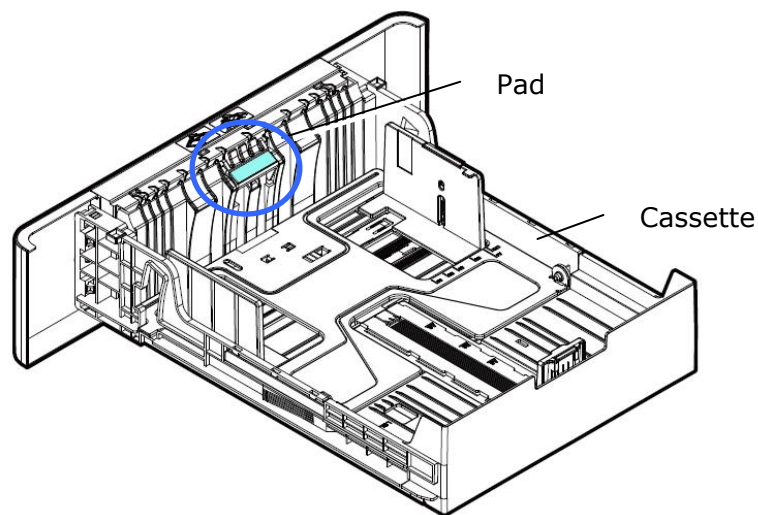

Important:

After cleaning the smeared Pad, dry it completely.

Cleaning the Drum Unit

If the drum unit is smeared with paper powder or dirt, the print out may appear defective image of regular interval. Follow the procedure below to clean the drum unit.

1. Turn off the power and remove the power cord from the power outlet.
2. Open the front cover by pulling the handles on both sides as shown.

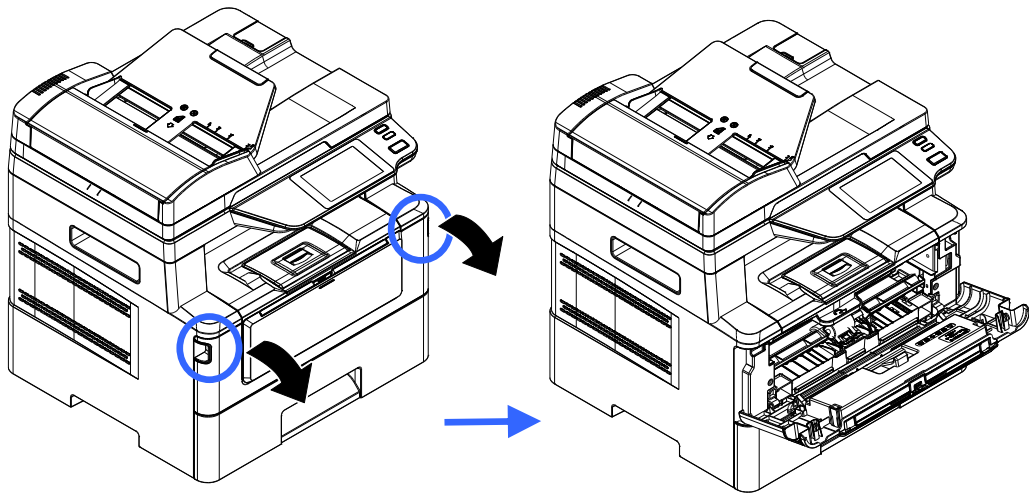

3. Lift the handle of the drum unit and toner cartridge assembly and gently remove the assembly.

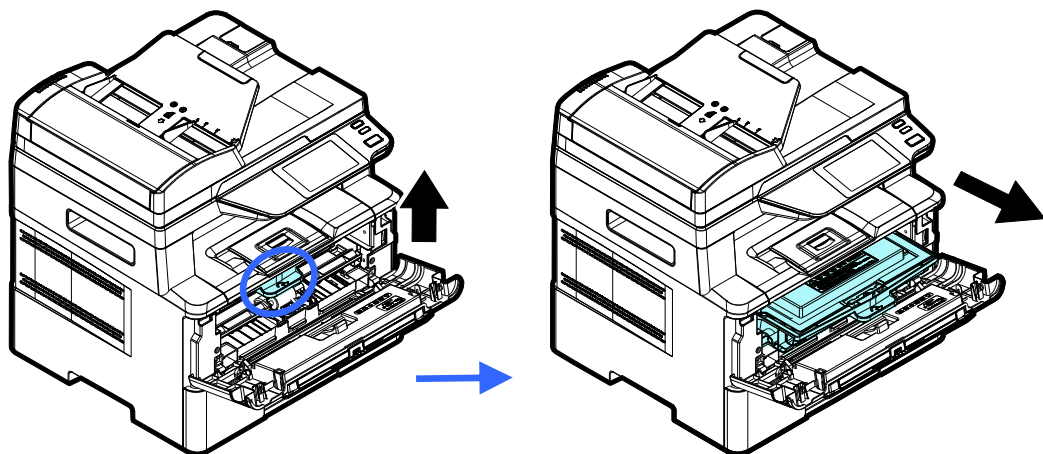

4. Remove the toner cartridge from the drum unit as shown.

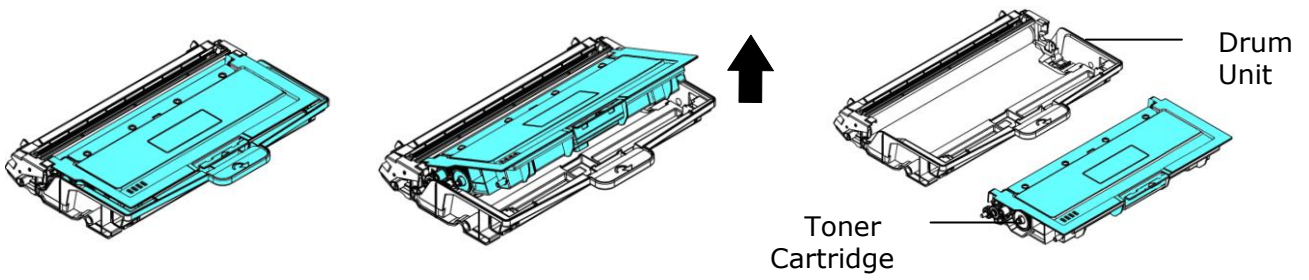

5. Clean the drum unit with a clean and soft cloth.

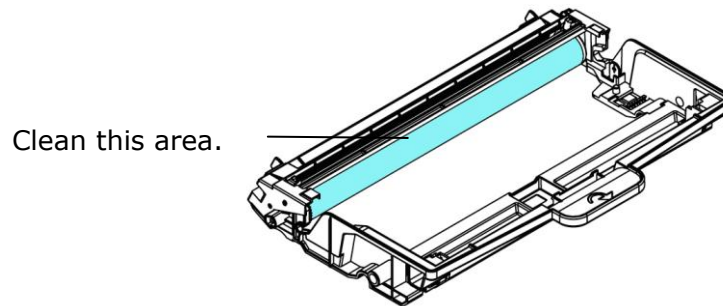

Cleaning the Paper Path

1. Refer to the preceding section to remove the Toner Cartridge.
2. Check if there is paper dust on the Paper Path. If so, remove the dust.

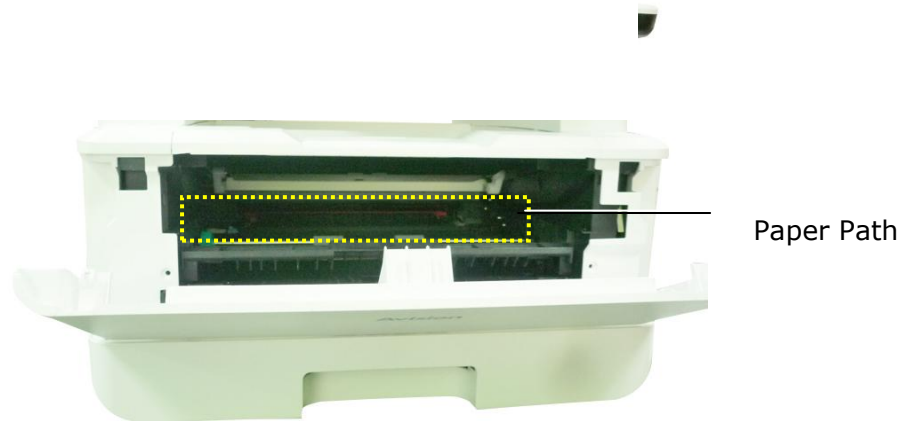

Cleaning the IR Sensors

If too much paper dust or dust accumulates on the IR sensors, it may cause the misjudgment of paper jam. For example, there is error code of paper jam occurs yet in fact no jammed paper found inside the printer. In this case, please clean the IR sensor according to the following steps. If the problem persists, the sensors are probably malfunctioning. Please contact the service personnel to replace the sensor.

1. Refer to the preceding section to remove the Toner Cartridge.
2. Moisten a clean, soft cloth with 95% alcohol.
3. Wipe the area near the sensors as indicated.

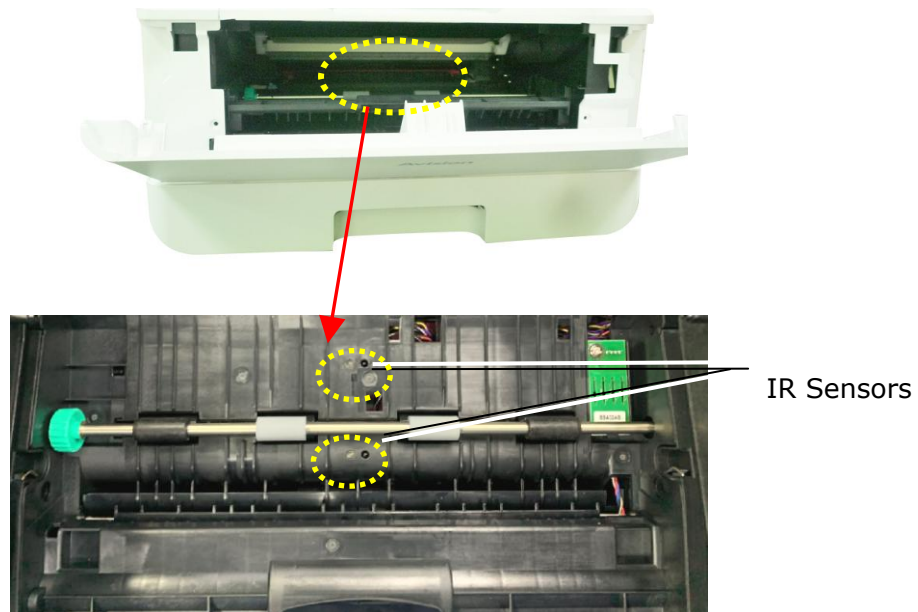

Cleaning the Paper-In Sensors

If too much paper dust or dust accumulates on the Paper-in sensors, it may cause the misjudgment of paper jam. For example, there is error code of paper jam occurs yet in fact no jammed paper found inside the printer. In this case, please clean the Paper-in sensor according to the following steps. If the problem persists, the sensors are probably malfunctioning. Please contact the service personnel to replace the sensor.

1. Turn off the power.
2. Remove the Paper Tray.
3. Moisten a clean, soft cloth with 95% alcohol.
4. Wipe the **Back** of the sensor board as indicated.

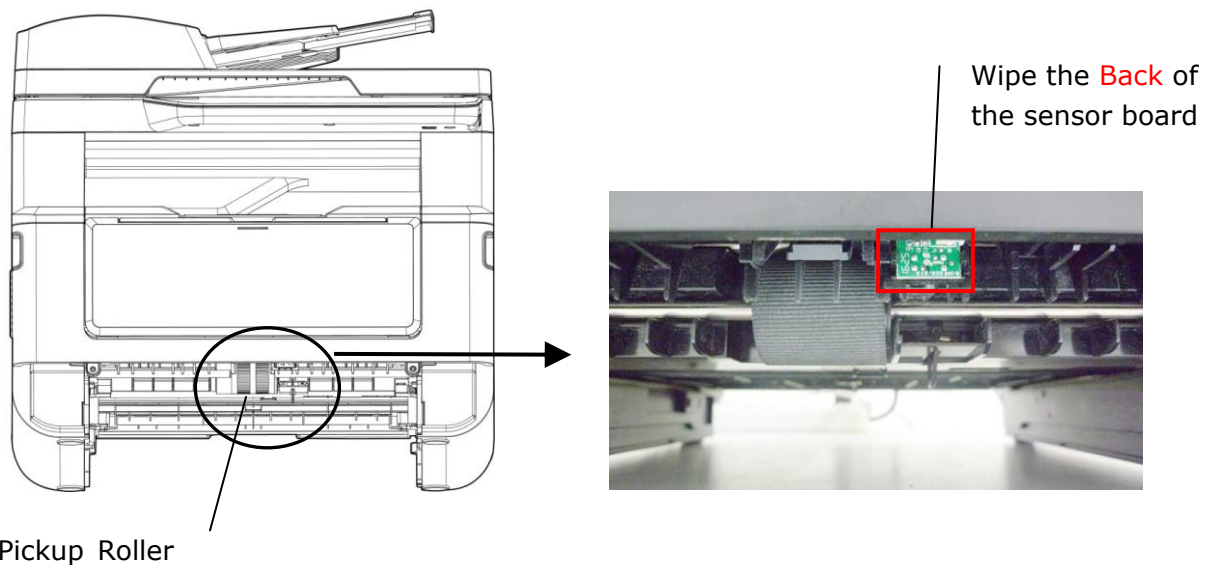

Important!

Before cleaning the paper-in sensor, make sure the power has been turned off and avoid touching the sensor board in case the components of the circuit board may be damaged.

Clearing the ADF Paper Jam

In the event of a paper jam in the ADF, follow the procedures below to remove the paper:

1. Gently open the ADF front cover to the left **1**.
2. Carefully pull the paper out of the ADF unit **2**.
3. Close the ADF front cover. Your product is now ready to use.

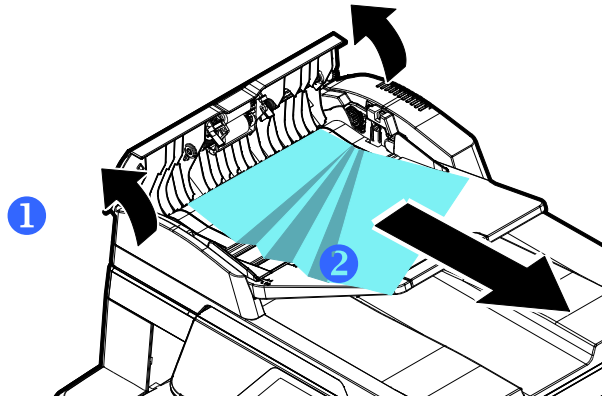

Replacing the Snap-in Pad Module

After scanning about 20,000 sheets through the ADF, the pad may be worn out and you may experience problems with document feeding. In this case, it is highly recommended to replace the pad module with a new one. For ordering the pad module, please consult your nearest dealer and follow the procedure below to replace it.

Disassembling Procedure

1. Gently open the ADF front cover.
2. Remove the ADF snap-in pad module by pressing the lock upward.

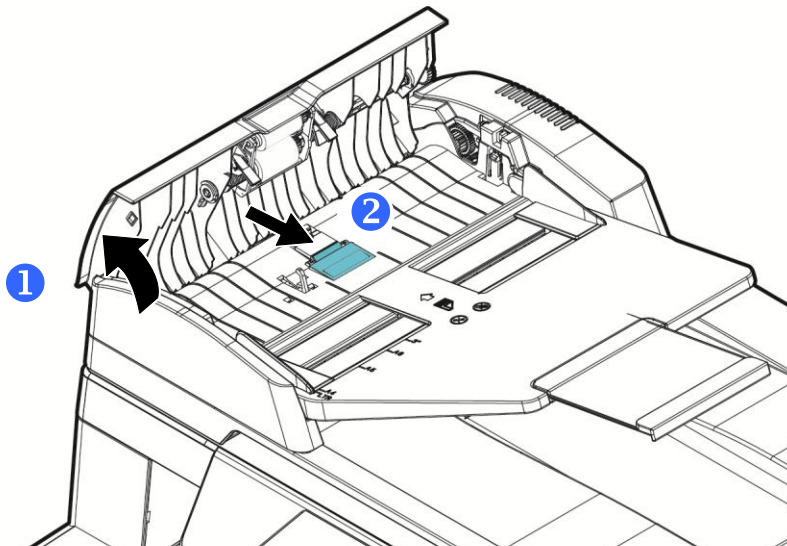

Assembling Procedure

1. Gently open the ADF front cover to the left.
2. Remove the ADF pad module from the box.
3. Place it into the holes until it snaps into place.

Replacing the Toner Cartridge

The toner cartridge that comes with the product needs to be replaced after printing approximately 3,000 pages. When the toner cartridge is running low, you will be prompted with a [**Toner Low**] message. Buy a new toner cartridge and have it ready before you receive [**Replace Toner**] message.



Note:

The drum unit and the toner cartridge are two separate parts.

Follow these steps to replace the toner cartridge:

Removing the Toner Cartridge

1. Turn off the power and remove the power cord from the power outlet.
2. Open the front cover by pulling the handles on both sides as shown.

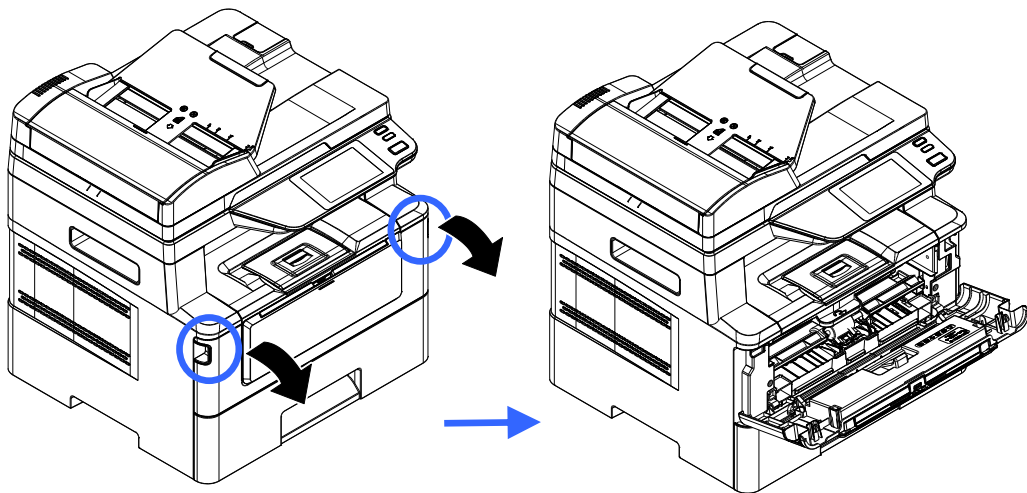

3. Lift the handle of the drum unit and toner cartridge assembly and gently remove the assembly.

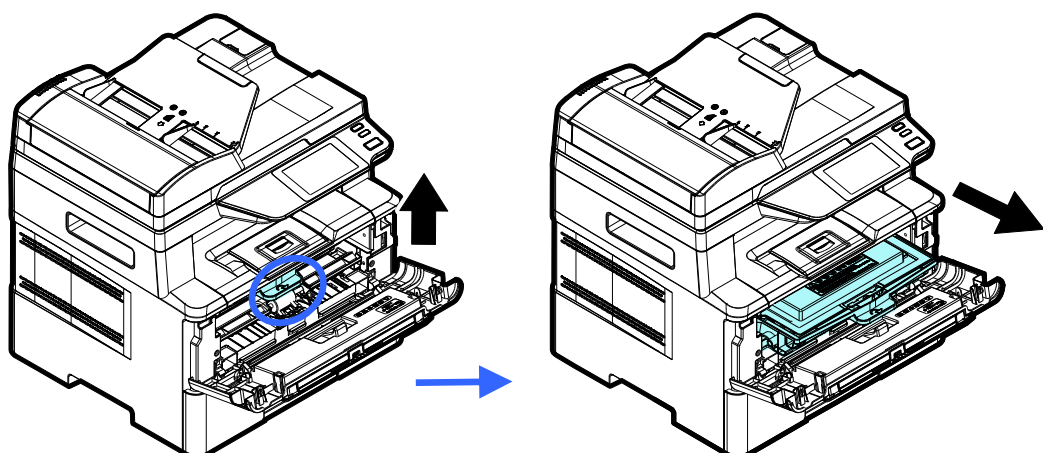

4. Remove the toner cartridge from the drum unit as shown.

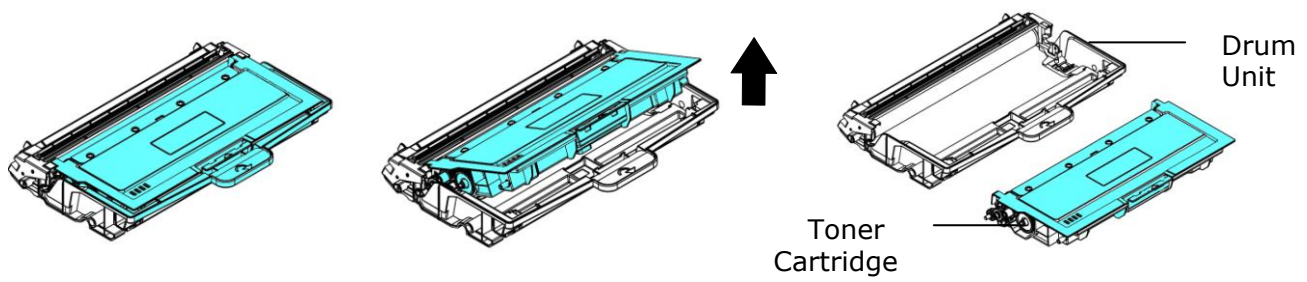

5. Insert the protective cover to the used toner cartridge and place it into its original box and return it to an authorized service center.

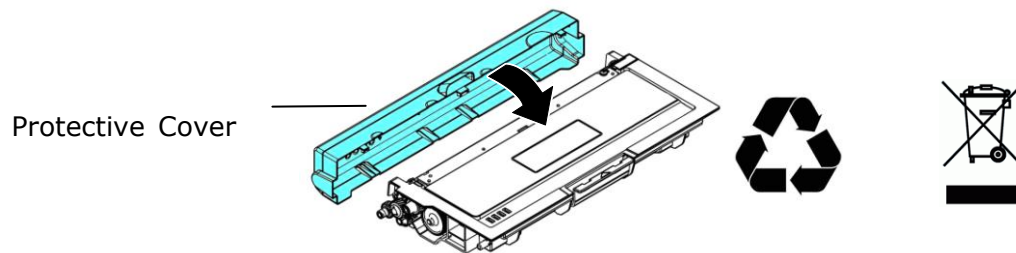

Important!

Do not dispose of the toner cartridge. Put the used toner cartridge into the bundled plastic bag, and then return it to a dealer or service representative. The latter recycles or deals with the collected toner cartridges in accordance with the relevant regulations.

Installing the Toner Cartridge

1. Unpack the new toner cartridge and remove the protective cover.

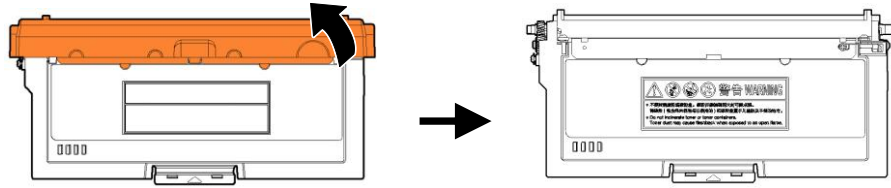

2. Pull out the protective seal of the toner cartridge until it is completely removed.

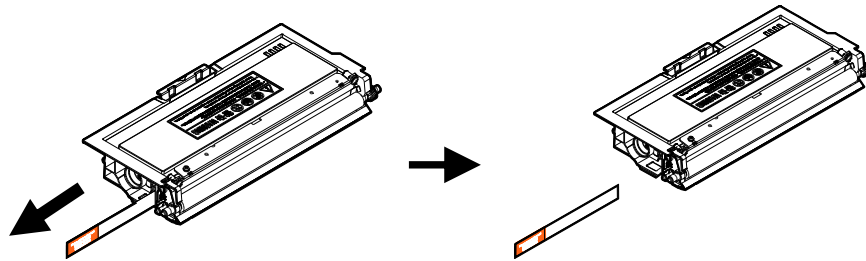

3. Tilt the toner cartridge up and down and then right and left 10 times to distribute the toner evenly inside the toner cartridge.

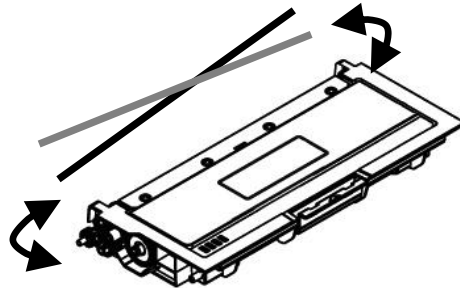

4. Install the toner cartridge to the drum unit.

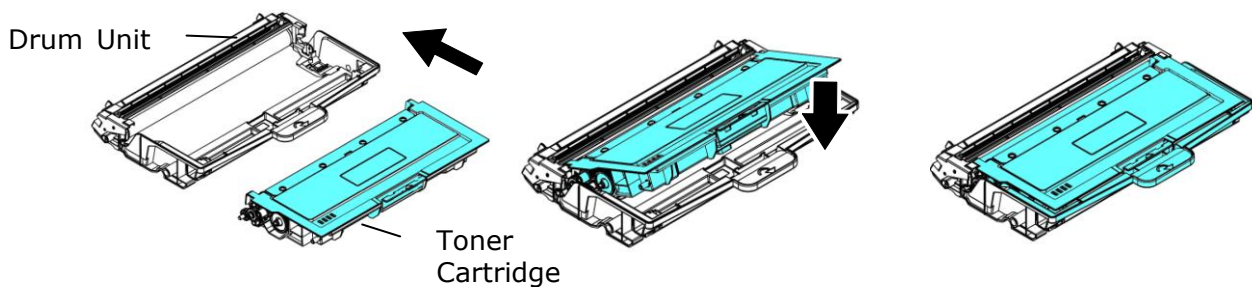

Warning!

- Be careful not to inhale toner.
- If toner gets on your clothing or other fabric, wipe off the toner with a dry cloth. Wash the items in cold water and air dry.
- To avoid print quality problems, DO NOT touch the toner rollers.
- To prevent the toner cartridge from damage, do not expose it more than several minutes.

5. Clean the corona wire inside the drum unit by gently sliding the tab from left to right and right to left for several times. (After the toner cartridge has been used for a period of time, some amounts of toner may remain on the corona wire.)

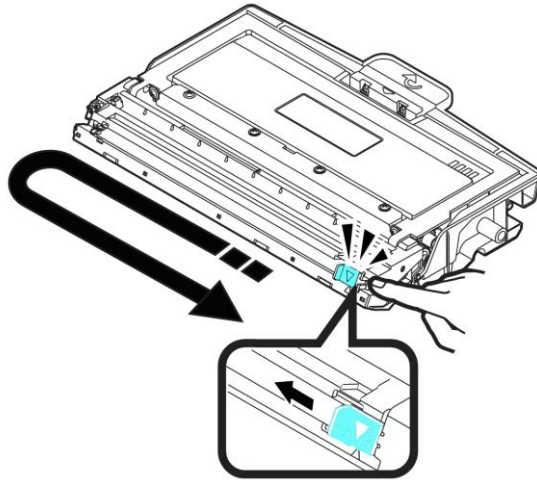

Note:

Be sure to return the tab to the Home position (▲). The arrow on the tab must be aligned with the arrow on the drum unit. If it is not, printed pages may have a vertical stripe.

6. Hold the handle of the toner cartridge assembly and insert the toner cartridge assembly to its original place. Press the handle to fix it firmly in place.

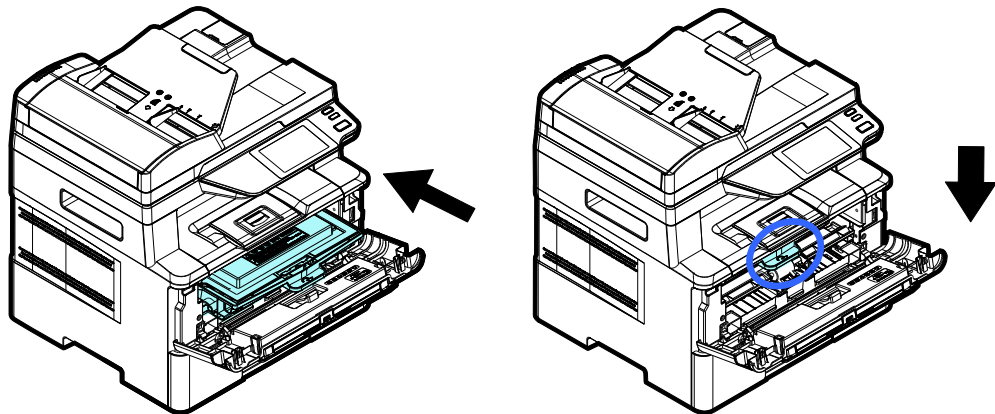

7. Close the front cover.

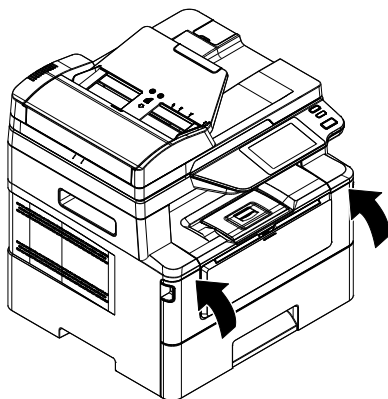

Replacing the Drum Unit

The drum unit that comes with the product needs to be replaced after printing approximately 12,000 pages. When the drum unit is running low, you will be prompted with a [**Drum Low**] message. Buy a new toner cartridge and have it ready before you receive [**Replace Drum**] message.

Follow these steps to replace the toner cartridge:

Removing the Drum Unit and the Toner Cartridge Assembly

1. Turn off the power and remove the power cable from the power outlet.
2. Open the front cover by pulling the handles on both sides as shown.

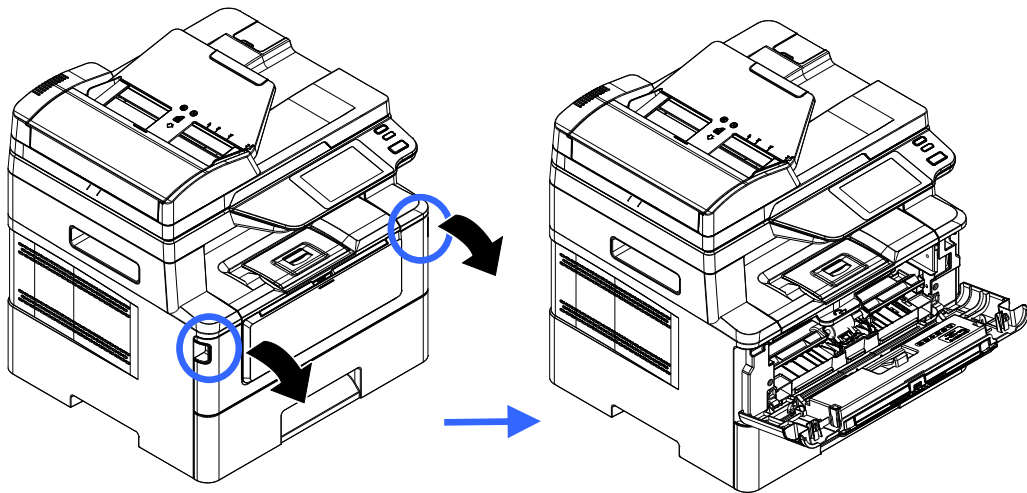

3. Lift the handle of the toner cartridge and gently remove the toner cartridge.

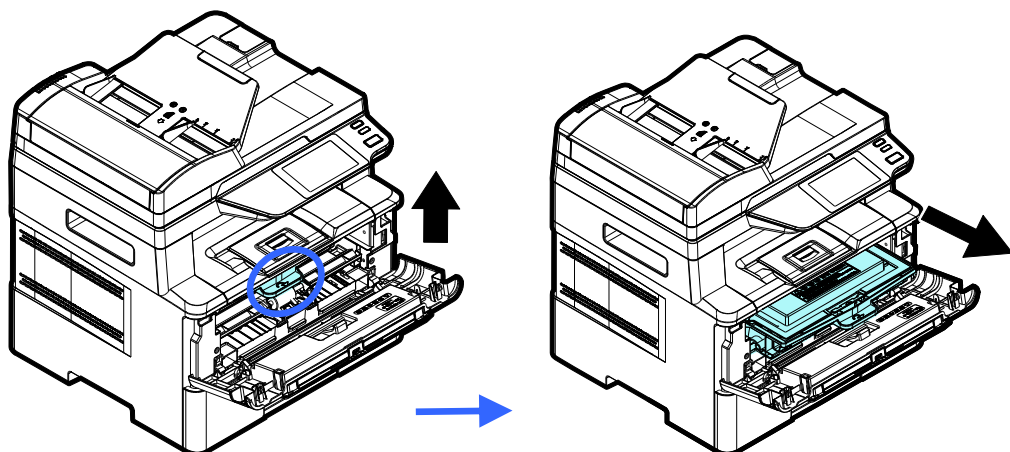

- 4.** Remove the toner cartridge from the drum unit as shown.

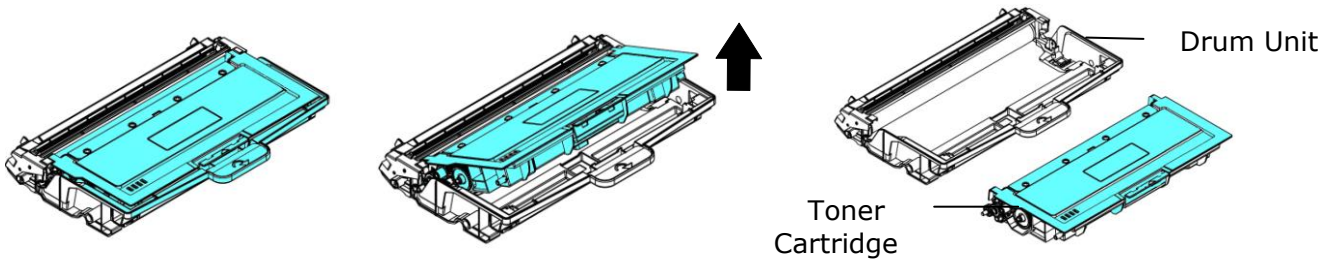

Installing the Drum Unit

- 1.** Remove the protective film and the label in the center of the drum unit. Be sure not to touch the drum during unpacking. Your finger print may effect the print quality.



- 2.** Install the toner cartridge to the new drum unit.

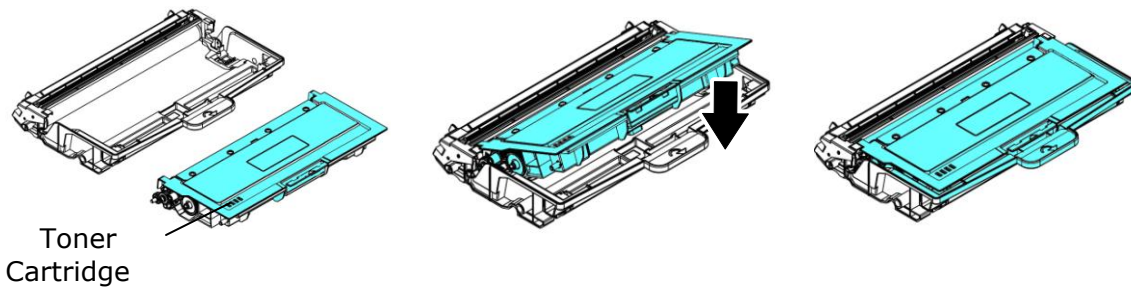

- 3.** Hold the handle of the toner cartridge and insert the toner cartridge to its original place. Press the handle to fix it firmly in place.

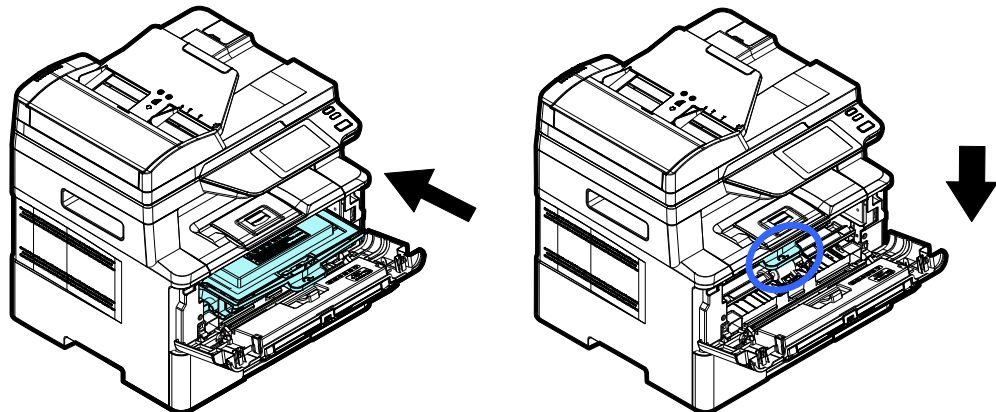

4. Close the front cover.

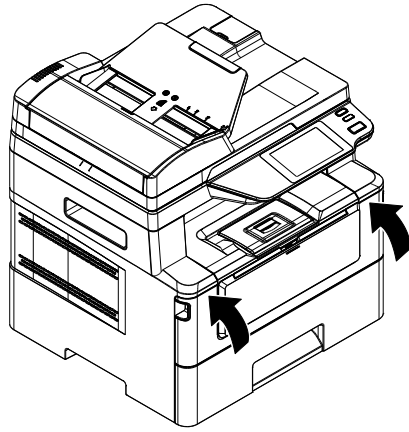

10. Troubleshooting

Monitoring Your Printer Using Printer Status Monitor

Printer Status Monitor allows you to monitor your printer's status, get information on consumable parts, and alerts you when printer errors occur.

Printer Status Monitor is available when the printer is connected directly to a host computer via the USB port or a network port.

Printer Status Monitor is installed when you install the printer driver as described in the preceding section.

Accessing Printer Status Monitor

Double-click the **Printer Status Monitor** icon on the system tray. The following printer status window appears.



Printer Status Monitor icon

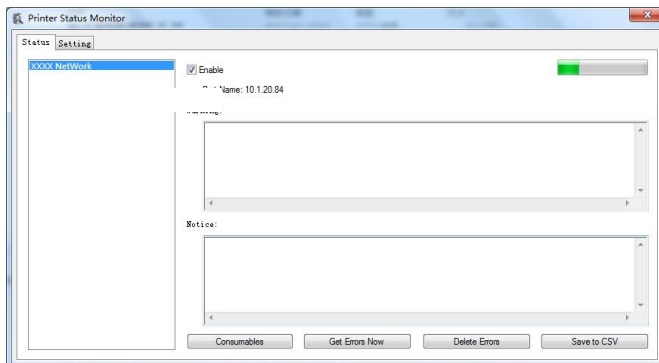

Printer Status Window

Getting Printer Status Details

You can monitor printer status and get information on consumable products using the Printer Status Monitor dialog box.

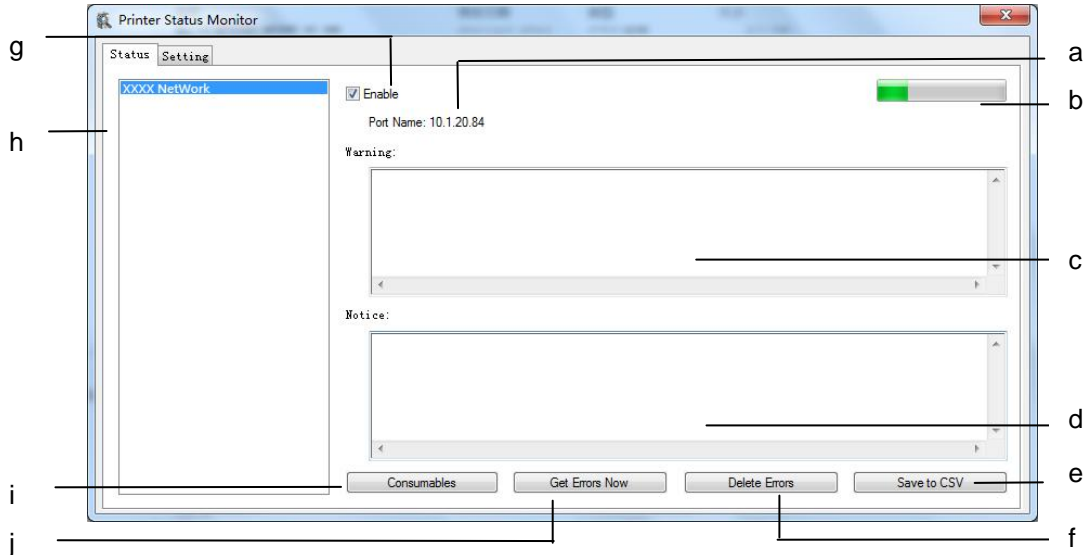

a Port Name	Port name for the specified printer.
b Progress Bar	The progress bar to access the latest data of the specified printer.
c Text Box	Display the warning message.
d Text Box	Display the notice message.
e Save Errors to CSV	Save error message to a CSV file.
f Delete Errors	Delete all the error messages.
g Enable	Check the box to enable accessing the status of a specified printer.
h Printer	Display connected printers.
i Consumables	Click to show the information of the paper tray and the consumables parts such as Drum(EP), Toner.
j Get Errors Now	Refresh the printer status.

Setting Monitoring Preferences

To make specific monitoring settings, click the Setting tab on the Avison Status Monitor window.

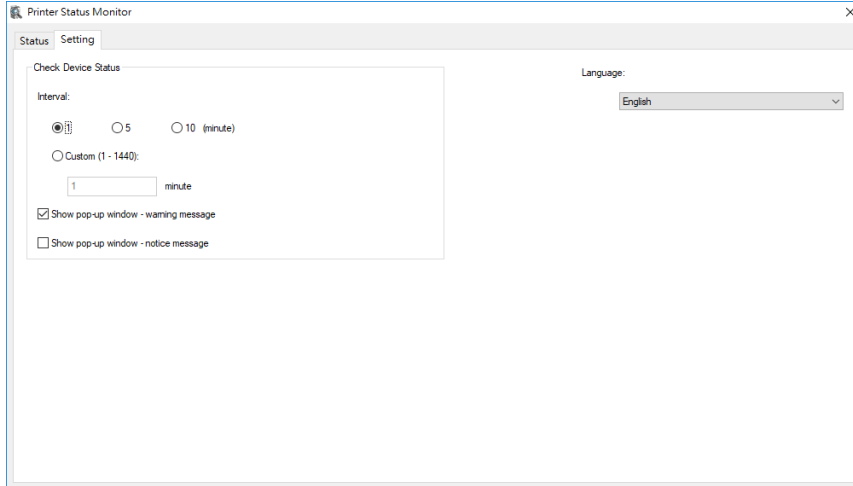

Language	Displays the language of the window.
<p>Status Alert</p> <p>Update Time</p> <p>Show pop-up window – warning message</p> <p>Show pop-up window – notice message</p>	<p>Define the interval to refresh the printer error status.</p> <p>Choice: 1, 5, 10 (minute), Custom (1 ~ 86400) second</p> <p>Check the box to automatically show the warning status in a pop-up window on the system tray.</p> <p>Check the box to automatically show the notice message in a pop-up window on the system tray.</p>

Clearing A Warning or Error Message

If a problem occurs during operation, a warning or error message and QR code will display on the LCD panel. In addition, the Error LED will be flashing or solidly lit to indicate a warning or an error status. To solve the problem, please follow the on-screen instruction and the following table for more detailed information.

Warning Message

Message	Description or Solution
Auto Temp. Adjust (200004)	Auto Temperature Adjustment. Please wait. The temperature inside the printer is too high. To avoid damaging the toner, the print job is suspended for a few minutes. After the temperature returns to the normal degrees, the warning message will then disappear and the print job will continue.
The fuser temperature too low (200006)	Job will be reprinted after temperature is normal.
No toner cartridge(200030)	Install toner cartridge.
Toner empty (200031)	Toner has run out. Replace a new toner cartridge.
Toner low (200032)	Toner that remains is lower than 10%. The machine can still perform printing or copying function yet with poor quality.
Toner low (200037)	Toner that remains is lower than 10%. The machine can still perform printing or copying function yet with poor quality.
No Drum unit (200041)	Please install Drum unit and restart MFP.
Drum unit life ends (200042) (200048)	Drum unit life time ends. Call the service personnel to order and replace the drum unit.
Drum unit near end (200043).	Drum unit that remains is lower than 10%. Call the service personnel to order and replace the EP.

Invalid drum unit (200044), (201504), (201514)	Please install the drum unit from the original vendor.
Drum unit changed (20046)	Drum unit has been changed. Restart the MFP.
Drum unit changed (20047)	Install correct drum type.
Invalid fuser (201502) (201512)	Please install fuser from the original vendor.

Error Message

Error Message and Codes	Possible Causes or Solution
System error	
Service code: 100111	Restart MFP. If this error persists, call service personnel for help.
IC2 error: 100112	Please call service.
USB Current Overload (100113)	Current overload for the USB drive near the control panel
USB Current Overload (100114)	Current overload for the USB drive on the main board
USB Current Overload (100115)	Current overload for both the USB drive near the control panel and the USB drive on the main board
Scan module error (000113) Restart MFP or call service.	An unexpected error from scanner parts occurs. Restart MFP or call service to replace scanner parts that fail.
ADF cover opens. Close ADF cover.(002014)	Close ADF cover.
ADF Multi-Feed. Open ADF cover.(003101)	Open ADF cover to remove paper.
Printer module error. Please restart MFP or call service (205000, 205001).	An unexpected error from printer parts occurs. Restart MFP or call service personnel to replace printer parts that fail.
Printer module error. Please clean corona wire and restart MFP or call service (205101).	An unexpected error from printer parts occurs. Please clean corona wire and restart MFP or call service personnel to replace printer parts that fail.
Motor error (000001). Press # button to erase or call service.	When MFP is booted, the scanner and printer engine Initialization fail. Restart MFP.
Scanner lamp error (002007). Please close flatbed cover and Press # button to erase or call service.	The CIS lamp is damaged or not lit. Call service personnel to replace the CIS unit.
Fan 1 fails (200090).	Call service personnel to replace the fan.

Fan 2 fails (200091).	Call service personnel to replace the fan.
Front cover opens (200051).	Please close front cover.
Rear cover opens (200054).	Please close rear cover.
Continue feed error (200000).	Please open front cover to clear the paper and load paper to proper tray.
Fuser error (201600, 201604~5, 201613, 201615~201618, 201621~201623)	Please restart MFP. If the error persists, call service personnel for help.
No matching paper (200001)	Please load correct paper size.
Please open rear cover (200002).	The rear cover has to be opened when bond, card, or transparency is selected as media type.
Toner Cartridge Error (200036)	Please install toner cartridge from the vendor.
Toner Cartridge Error (200038)	Please install toner cartridge from the vendor.
Toner Cartridge Error (201505)	Please install toner cartridge from the vendor.
Toner Cartridge Error (201515)	Please install toner cartridge from the vendor.
Please load paper in manual tray (200080).	Paper empty in the manual tray.
Please load paper to tray1 (200081)	Tray 1 paper empty.
Please check tray 1 and press OK (200003).	Pick up error. Paper empty, paper jam, or pickup failed in tray 1.
Font package is not installed. Please contact administrator (940201)	Please install Chinese font.
USB flash disk not found.	Insert USB flash drive to the USB flash port.
USB flash disk connection fails. Job abort.	Check the connection of USB flash drive.
MFP not ready. Try again later.	MFP is busy with current job. Wait until current job is completed.
Buffer full Job abort.	Memory is not enough to process the scanned images.

Buffer full Print scanned images : 1 Cancel job : 2	Memory is not enough to process the scanned images. Press [1] to print the first few images which have not exceeded the memory limit or press [2] to cancel job.
It seems both sides are blank images. If not, please try to copy from the platen glass	Check your original and try to copy from the platen glass.
Resetting default settings fails. Please try again later.	Resetting default settings.
Scanner Calibration fails. Please try again later.	Please try again by pressing the Menu button and then choosing System>Management>Calibration.
Reset count fail. Please try again later.	Please try again by pressing the Menu button and then choosing System>Management>Reset count.
Reset default fail.	Please download again.
Setting fails. Please try again later.	Setting the Menu option fails. Check your setting.
Full page not support N in 1	The Full page feature does not support N in 1 (2 in 1 or 4 in 1).
Custom zoom not support N in 1	The Custom Zoom feature does not support N in 1 (2 in 1 or 4 in 1).

Sending to FTP/SMB Errors	
Failed to receive data from the network.	Tray again.
Invalid login name or password.	Please check your login name or password on the product's web page.
Connection failed. Unable to connect to server.	Connection fails during scan to FTP/SMB. Check network environment or tray again later.
JPG not support Black&White	JPG file format does not support black and white image mode.
E-Mail Errors	
Enter a valid E-mail address	Enter a valid E-mail address
Exceed allowable limit.	E-mail recipients exceed allowable number (20).
Number of group member exceeds limitation (20)	Reduce group members.
Number of group exceeds limitation (10)	Reduce groups.
Number of address book exceeds limitation (500)	Reduce address book members.
No recipients added. Please add recipients before pressing start.	Enter your recipient.
No from address added.	Please add address in the [From] field, before pressing start.
File name is existed.	File name for the scanned image existed.
Job abort.	Change your file name.
JPG not support Black&White	JPG file format does not support black and white image mode.
No entries found. Please modify your search entry.	
Unknown error.	Restart MFP. If this error persists, call service personnel for help.

USB Print Errors	
Error in printing PDF file over 32MB.	Please reduce your page number or file size
Can not print the PDF file	Change your file format.
Only the first 100 files will be displayed in the list	Number of files in your USB drive exceeds 100.
Your PDF file reached maximum 1000 pages.	Reduce your page number.
Job abort by blank pages	Check your original.
USB port connection error, data transmission is not complete	Check USB flash drive connection.
File contents error, unable to support print	Check your file contents.
Data decompression time out	Please try again.
Data decompression checksum fail	Please try again.

Network Errors

Error Code	Cause	Solution
500000	IP Conflict : The same IP address is detected in the network environment by the product.	DHCP: require a new set of unique IP address from DHCP Server. Static IP : reset the native IP address.
500001	Net Cable Unplug : The RJ-45 port without a network cable plugged in is detected.	Connect the network cable.
500002	DHCP has no response: When the product is connected to the network via DHCP, the DHCP Server has no response to the request from the product.	Network connection failure. The solution: Use the static IP or connect to a network environment with a DHCP server.
500003	Can not connect to network.	Check your network.

Error Message and Codes	Possible Causes or Solution
System error	
Error (Number).	Restart MFP. If this error persists, call service personnel for help.
300100	Printer API_NVRAM_RW_TEST_FAIL
300101	Printer API_NVRAM_WRITE_FAIL
300102	Printer API_NVRAM_READ_FAIL
300200	Printer Flash Error
300201	Printer FLASH_BLOCK_ERASE_FAILED
300202	Printer FLASH_CHIP_ERASE_FAILED
300203	Printer FLASH_PROGRAM_FAILED
201516	Write Data Smaller Error – Engine
201610	Printer LPH Error. Reconnect LPH cable
201631	Black LPH Type Error
201632	Red LPH Type Error
201650	Printer runtime error
201651	Firmware error
201701	Printer MB NVRAM : reading error
201702	Printer MB NVRAM : writing error
201703	Printer MB NVRAM : reading error while comparing
201704	Printer MB NVRAM : comparing error
201711	Printer Drum Unit NVRAM : reading error
201712	Printer Drum Unit NVRAM : writing error
201713	Printer Drum Unit NVRAM : reading error
201714	Printer Drum Unit NVRAM : comparing error
201721	Printer Toner NVRAM : reading error
201722	Printer Toner NVRAM : writing error
201723	Printer Toner NVRAM : reading error while comparing
201724	Printer Toner NVRAM : comparing error
201730	Printer uses wrong NVRAM Address.
302651	Network_INIT_FAIL , network initialization fails.

Fuser Errors

Error Code	Problem Cause on Fuser	Solution
201600	Lamp heating exceeds the upper temperature limit (210 degrees).	<ol style="list-style-type: none"> 1. Restart the machine. 2. If the error code persists, replace the fuser.
201604	Analog to Digital conversion (ADC) adjustment not ready.	
201605	Analog to digital conversion not ready: In a non-initial state, query on the A3 and A4 lamps' ADC values per 500ms fails.	
201613	The difference between the current and last temperatures of the A4 lamp is more than 20 degrees.	
201615	In the warming state, the A4 lamp does not heat up over 7 degrees in 10 seconds, which means a heating error occurs.	
201616	Fuser heating from ready to print status is over 14 seconds.	
201617	Fuser heating from warming to ready status is over 18 seconds.	
201618	Fuser heating from starting to ready status is over 8 seconds.	
201621	The machine detects that the lamp's center thermistor is not connected.	
201622	The machine detects that the lamp's side thermistor is not connected.	
201623	The temperature of the side thermistor does not raise to the specified degrees.	
201626	HW Flicker signal abnormal or not received.	
201630	The device detected the environmental thermistor not connected.	
201635	Fuser zero cross positioning failed.	

Paper Jam
ADF paperjam (002013). Please open the ADF to remove the jam paper.
Paper feed failed (200301). Please check manual tray.
Paper feed failed (200302). Please check tray 1 and clear the jammed paper.
Paper jam (200324). Please open front cover and tray 1 to clear jam paper.
Paper jam (200325). Please open front cover and pull drum unit out to clear jam paper.
Paper jam (200326). Please open front cover and pull drum unit out to clear jam paper.
Paper jam (200327). Please open front cover and pull drum unit out to clear jam paper.
Paper jam (200328). Please open front cover and pull drum unit out to clear jam paper.
Paper jam (200329). Please open front cover and pull drum unit out to clear jam paper.
Paper jam (200330). Please open front cover and rear cover to clear jam paper.
Paper jam (200331). Please open front cover and rear cover to clear jam paper.
Paper jam (200332). Please open front cover and rear cover to clear jam paper.
Paper jam (200333). Please open front cover and rear cover to clear jam paper.
Paper jam (200334). Please check the duplex tray and open front cover and rear cover to clear the jam paper.
Paper jam (200335). Please check the duplex tray and open front cover and rear cover to clear the jam paper.

Locations of the Jammed Paper

Front Cover: Open the front cover by pulling the handles of the front cover on both sides as illustrated.

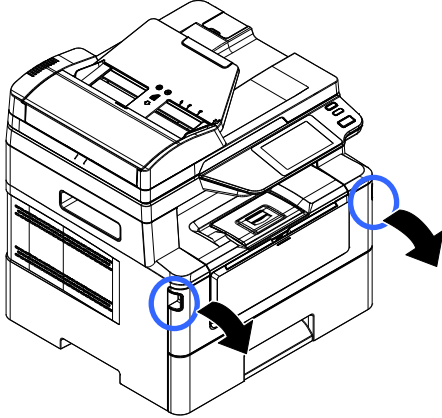

Rear Cover: Open the rear cover by pulling the handle of the rear cover as shown.

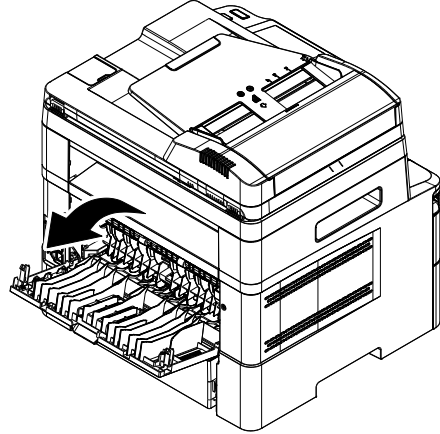

Duplex tray: Pull the duplex tray beneath the rear cover out of the main unit.

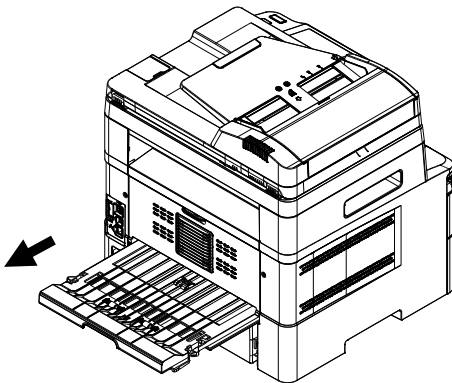

Manual Tray: Pull the handle to open the manual tray.

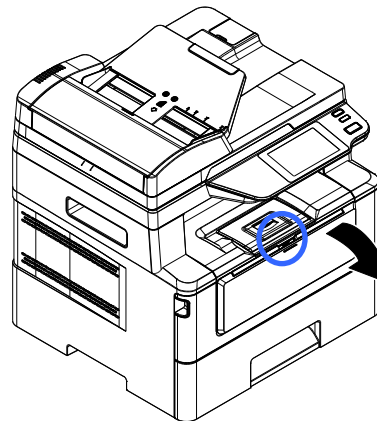

Fuser:

The area around the fuser is hot. To avoid a burn injury, be careful not to touch the fuser until it cools down and follow these steps to remove the jammed paper:

- 1.** Open the **Front Cover** and the **Rear Cover**.

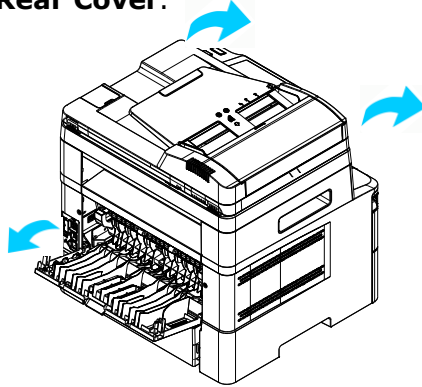

- 2.** Pull down the **Fuser Path** as indicated.

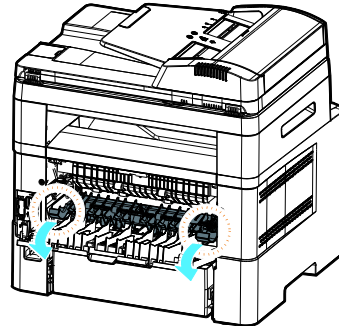

- 3.** Pull down the **Release Arm** on both sides.

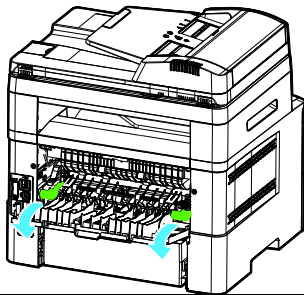

- 4.** Slowly remove the jammed paper.

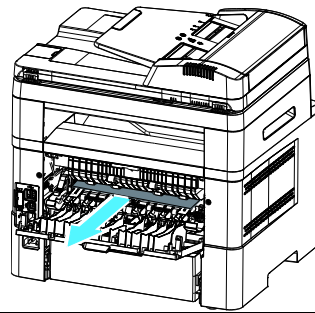

- 5.** If there is difficulty to pull off the jammed paper, remove the printer cartridge first.

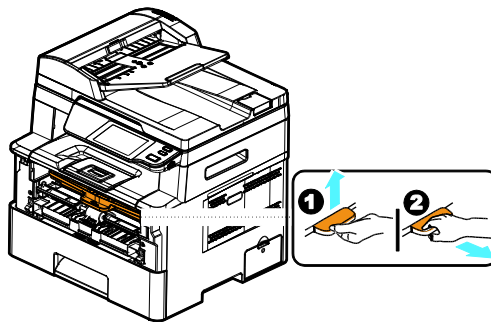

- 6.** Rotate the Release Wheel to slowly pull out the jammed paper.

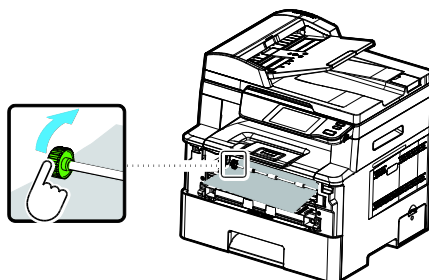

Image Problem Troubleshooting





Problem	Image Example	Solution
Paper curls		<ol style="list-style-type: none"> 1. Use paper of standard weight: If you are using thin paper, try to use paper of standard weight (80 g/m²). 2. Use paper with less moisture: Load the paper to the paper tray immediately after removing them from the packaging. Seal the remaining paper with the original packaging to keep from the moisture absorption.
Light print(entire page)		<ol style="list-style-type: none"> 1. Make sure that the toner cartridge is fully installed. 2. Make sure that the Toner Save setting is turned off in the printer driver. 3. Try using a different type of paper. 4. The toner cartridge might be almost empty. Replace the toner cartridge.
Light print(partial page)		<ol style="list-style-type: none"> 1. Make sure that the toner cartridge is fully installed. 2. The toner level might be low. Replace the toner cartridge. 3. The paper might not meet the printer's specifications (for example, the paper is too moist or too rough).
Vertical white lines		<p>Call the service personnel for help.</p>
Vertical black lines		<p>Please clean the EP charger (corona wire) according to the procedure described in this manual on page 138.</p>

Image Problem Troubleshooting

Problem	Image Example	Solution
Dirty background(partial page)		<p>Check if toner is not leaked from the toner cartridge. If so, replace the toner cartridge.</p>
Dirty background(entire page)		<ol style="list-style-type: none"> 1. The paper might not meet the printer's specifications (for example, the paper is too thin). 2. Check if there is enough toner in the toner cartridge. If not, please replace the toner cartridge. 3. Call the service personnel for help.
Print blank page		<p>Check if there is enough toner in the toner cartridge. If not, please replace the toner cartridge.</p> <p>If this error happens again, call service for help.</p>
Defective image of regular interval		<ol style="list-style-type: none"> 1. Clean the drum unit with a soft and clean cloth (See p. 128). 2. If this error happens again, call service for help.
Loose toner		<ol style="list-style-type: none"> 1. If you have observed a rougher texture on one side of your paper, try printing on the smoother side. 2. The paper might not meet the printer's specifications (for example, the paper surface is not smooth or paper too thick). 3. Media type incorrect. Please choose proper media type for your paper.

Black line on edge		The image is slightly skew. Make sure the edge of your document is properly aligned and slightly touch the paper guides in the auto document feeder.
--------------------	---	--

Technical Support

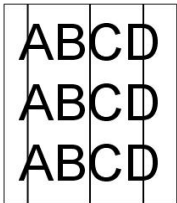
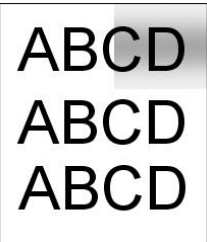
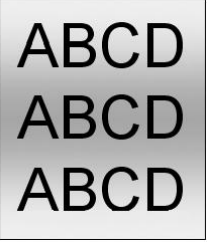
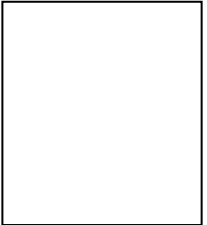
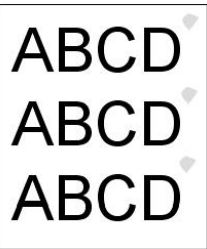
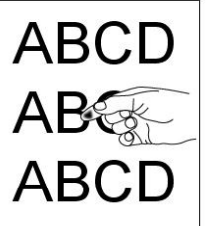
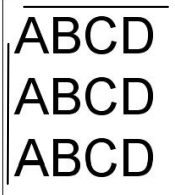
If your problem still exists after trying the above solution, please contact our technical support.

Headquarter

Avision Inc.

No. 20, Creation Road I, Science-Based Industrial Park,
Hsinchu 300, Taiwan, ROC
TEL: +886 (3) 578-2388
FAX: +886 (3) 577-7017
E-MAIL: service@avision.com.tw
Web Site: <http://www.avision.com.tw>

US and Canada Area

Avision Labs, Inc.

6815 Mowry Ave., Newark CA 94560, USA
TEL: +1 (510) 739-2369
FAX: +1 (510) 739-6060
E-MAIL: support@avision-labs.com
Web Site: <http://www.avision.com>

China Area

Shanghai Technical Support Center

7A, No.1010, Kaixuan Road, Shanghai 200052 P.R.C.
TEL :+86-21-62816680
FAX :+86-21-62818856
E-MAIL :sales@avision.net.cn
Web Site:<http://www.avision.com.cn>

Europe Area

Avision Europe GmbH

Bischofstr. 101 D-47809 Krefeld Germany
TEL: +49-2151-56981-40
FAX: +49-2151-56981-42
E-MAIL: info@avision-europe.com
Web Site: <http://www.avision.de>

Espaço Brasil

Avision Brasil Ltda.

Avenida Jabaquara, 2958 – Cj. 75 – Mirandópolis –
CEP: 04026-500 – São Paulo, Brasil
TEL: +55-11-2925-5025
E-MAIL: suporte@avision.com.br
Web Site: <http://www.avision.com.br>

11. Specifications

All specifications are subject to change without notice. For detailed specifications, please refer to our web site at <http://www.avision.com>

General		
Type	MFP Print-Copy-Email-Scan	
Touch Screen	4.3 inches	
Dimension (WxDxH)	404 x 380 x 413 mm	
Weight	10.7 kg	
Main Tray	Paper Capacity	550 Pages (70 g/m ² · Plain Paper)
	Paper Size	A4, A5, A6, B5, Letter, Legal, Legal 13, Oficio Custom size: 76 x 127 ~ 216 x 558 mm
	Paper Weight	60~120 g/m ²
Manual Tray	Paper Capacity	10 Pages (70 g/m ² · Plain Paper)
	Paper Size	A4, A5, A6, B5, Letter, Legal, Legal 13, Oficio Custom size: 76 x 127 ~ 216 x 558 mm
	Paper Weight	60~163 g/m ² (10 Page) 60~200 g/m ² (1 Page)
Duplex Print	Paper Size	Legal, Legal 13, Oficio, Custom Size (>B5), A4, B5, Letter
	Paper Weight	60~105 g/m ²
ADF Capacity	75 Pages (70 g/m ² · Plain Paper)	
ADF Paper Weight	60~105 g/m ²	
Connectivity	Hi-speed USB 2.0 (Device/Host) (Compatible with USB 3.0) 10/100/1000 Base-Tx Ethernet Wi-Fi: 802.11 b/g/n (For the model supports Wi-Fi)	

Operating Environment	Temperature	10°C ~ 32 °C
	Humidity	15% ~ 80% RH
Storing Environment	Temperature	-40°C ~ 65°C
	Humidity	10% ~ 90% RH
Current consumption		110~127Vac, 50/60Hz,9A Or 220~240Vac, 50/60Hz, 4.5A
Toner cartridge lifetime		3,000 prints
Drum unit lifetime		*30,000 prints
Product Lifetime		5 years or 120,000 prints
Copy Function		
Copy size		Legal, Oficio, Letter, A4, A5, B4(ISO), B5(ISO)
Copy speed		40 cpm (A4, 1 to N)
Copy count		up to 99, Auto Reset to 1
Print Function		
Printing method		Mono Laser
Printing speed		40 ppm (A4)
Printer driver		Windows 7, Windows 8, Windows 10, Windows 11 Linux (optional)
Max print size		216 x 356 mm (8 x 14 in.)
Min print size		76.2 x 127 mm (3 x 5 in.)
Resolution		1200 x 1200dpi
PDLs/Emulations		GDI/PCL/PS
First print out time		<5.9 seconds
Duplex print		Legal, Legal 13, Oficio, A4, B5, Custom Size (>B5), Letter

*Drum yield is based on 3 pages per job [letter/A4 simplex].

The number of pages maybe affected due to the media type or paper size.

Scan Function	
Scanner type	Flatbed/ADF/CIS type, Color/BW/Gray
Max. scanning size	Legal (216 x 356 mm) (ADF) A4 (216 x 297 mm) (Flatbed)
Min. scan size	76 x 127 mm
Optical resolution	1200 x 1200 dpi
Scanning bit depth	Color - 24bit(output)/48bit (input) Gray - 8bit(output)/16bit (input) B/W - 1bit
File format	M-PDF, PDF, JPG (not support B&W), BMP (for B&W only), TIFF, M-TIFF
Scan to Destinations	Scan to Device, Scan to E-mail, Scan to FTP/SMB, Scan to USB flash drive (partition type FAT16/FAT32)

Wi-Fi Specifications:

The model (CF-811AC/CF-WU810N) of Wi-Fi module varies according to countries/regions.

Model: CF-811AC

Main Chipset	RTL8811CU
Host Interface	USB 2.0
Frequency Range	2.4GHz/5.8GHz Dual-Channel
Wi-Fi Standard	IEEE802.11a
	IEEE802.11b
	IEEE802.11g
	IEEE802.11n
	IEEE802.11ac
Transmit Speed	11b : 1/2/5.5/11Mbps
	11g : 6/9/12/18/24/36/48/54Mbps
	11n : 200Mbps
	11ac : 433Mbps
Transmit Power	Max. 17 dBm
Security	WPA-PSK/WPA2-PSK
	WPA/WPA2
	WEP
Operating System	Windows XP/Vista/7/8/8.1/10 (32/64 bit)
	MacOS10.6~MacOS10.15

Model: CF-WU810N

Main Chipset	RTL8188EUS
Host interface	USB 2.0
Frequency Range	2.412~2.484 GHz
Wi-Fi Standard	IEEE 802.11b IEEE 802.11g IEEE 802.11n
Transmit Speed	11b: 1/2/5.5/11 Mbps 11g: 6/9/12/24/36/48/54 Mbps 11n: 150 Mbps
Transmit Power	Max. 18 dBm
Security	WPA-PSK/WPA2-PSK WPA/WPA2 WEP
Operating System	Windows XP/Vista/7/8/8.1/10 (32/64 bit) Max OS 10.6 ~10.11 Linux Kernel 2.6.18~3.10